

ATR8000

OWNER'S MANUAL

SWP Inc
MICROCOMPUTER PRODUCTS

2500 E. Randol Mill Road — 125
Arlington, Texas 76011
817/469-1181

Handwritten notes:
9171
10-12
1-4
649-5064
Tech Support 817-867-0424
Tans... 714-985-1055
D... Inc.

SWP Microcomputer Products, Inc., reserves the right to make hardware, software and pricing changes without notice.

Copyright c 1982
by SWP Microcomputer Products, Inc.,
Arlington, Texas.

All rights are reserved. Reproduction or use of this manual, without expressed permission in writing, in any form, is prohibited. This manual may not, in whole or in part, be copied, photocopied, reproduced, translated, reduced to any electronic, chemical, or magnetic storage system, or be translated into machine readable form without prior consent, in writing, from SWP Microcomputer Products, Inc., 2500 E. Randol Mill Rd., Suite 125, Arlington, Texas, 76011.

Printed in the United States of America

ATARI 800, ATARI 400, ATARI 810 Disk Drive, ATARI 820 Printer, ATARI 822 Printer, ATARI 825 Printer, ATARI 830 Modem, ATARI 850 Interface Module, and ATARI DOS are all registered trademarks of ATARI, Inc.

ATR8000 and CO-POWER-88 are trademarks of SWP Microcomputer Products, Inc. (Formerly Software Publishers, Inc.)

CP/M and CP/M-86 are registered trademarks of Digital Research, Inc.

D.C.Hayes Smart Modem is a trademark of Hayes Microcomputer Products, Inc.

IBM-PC is a trademark of IBM Corporation.

MSDOS is a trademark of Microsoft Corporation.

OS/A+ is a trademark of Optimized Systems Software, Inc.

Percom is a trademark of Percom Data Company.

Tandon is a registered trademark of Tandon Magnetics.

TRS-80 I and III are trademarks of Tandy Corporation.

Z-80 is a trademark of Zilog, Inc.

Table Of Contents

	<u>Page</u>
I. Introduction	7
1. The ATR8000 System	8
2. Power Requirements	8
3. Connecting the ATR8000 System: The Basics	9
A. Materials Needed	9
B. Disk Drive Basics	9
C. Printer Basics	10
D. ATARI 850 Basics	10
E. Making the Connections	10
II. The Connection in Detail	12
1. Cable Specifications	13
A. RS-232 Serial Printer Cable	13
B. Standard Centronics Parallel Printer Cable	14
C. Nonstandard Centronics Parallel Printer Cable	14
D. Standard Drive Cable	15
2. ATR8000 Port Specifications	16
A. RS-232 Port	16
B. FLOPPY DISK Port	17
C. PRINTER Port	18
D. The COMPUTER IN and PERIPHERAL OUT Ports	20
3. Peripherals	21
A. Disk Drives	21
1. ATARI 810 Drives	22
2. Percom Drives	22
3. Using All 5 1/4" Drives	24
4. 8" Drives	24

A. Using ATARI 810s, 5 1/4" and 8" Drives	25
B. Modems	26
1. ATARI 830 Modems	26
2. Modems for CP/M	26
C. Printers	27
1. 40 Column Printers: an ATARI 820 or 822	27
2. 80 Column and 132 Column Printers if an ATARI 850 is not Interfaced to the System	27
3. 80 Column and 132 Column Printers if an ATARI 850 is Interfaced to the System	27
D. The ATR8000's Ports and Possible Peripherals	28
4. Internal Drive Configuring	29
A. 5 1/4" Drives	29
1. Configuring 5 1/4" Tandons and Some Percom Drives	30
2. Configuring MPI, Aerocomp and Some Percom Drives	31
3. Configuring Shugart 400s	31
4. Configuring Shugart 460 Drives	32
5. ATARI 810 Drives	32
6. Radio Shack Drives	33
A. Redoing a Model I Drive to Run on Either the TRS 80 or the ATR8000	33
B. Redoing a TRS 80 Drive to be a Standard Disk Drive	36
B. 8" Drives	37
1. 8" Drive Configurations for Shugart 800s and 801s	37
2. Configuring Tandon Thinline Drives (848-1)	37
5. Protection from Radio Frequency Interference	38
A. Radio Frequency Interference on Nonconnected Radio-TV	38
B. Radio Frequency Interference Within the ATR8000 System	38
6. The Connection	40

A. ATARI, ATR8000, 1+ Standard Drives, Cables, One 8" Adapter for Each 8" Drive	40
B. ATARI, ATR8000, 1+ Standard Drives, 1+ ATARI 810s, Cables, One 8" Adapter for Each 8" Drive	44
C. ATARI, ATR8000, 1+ Standard Drives, 1+ ATARI 810s, Printer, Modem, ATARI 850, Cables, One 8" Adapter for Each 8" Drive	44
1. Connection Without the 850	45
2. Connection With the 850	45
3. Connecting a 40 Column Printer	46
D. Other Connections	47
7. ATR8000 Jumper Options	49
A. 16k or 64k	49
B. ATARI or RS-232 Terminal	49
C. 2k or 4k Operating ROM	50
D. Disabling the ATR8000 Printer Ports	50
E. RS-232 Configuring	51
8. Connecting an RS-232 Terminal to the ATR8000	53
III. Software	54
1. ATARI DOS	55
A. Booting ATARI DOS	55
B. Copying ATARI DOS to an 8" Disk	55
1. Booting ATARI DOS from an 8" Disk	56
C. Disks	56
1. Hard Sectorred Disks	56
2. Flipped Disks	57
D. Modems	58
1. PRINTOFF.BAS	59
2. PRINTON.BAS	60
E. Printers	61

1. Printing Features in the ATR8000 ROM	61
2. SERDRV.BAS: a Serial Printer Driver for ATARI DOS and OS/A+	62
F. ATRMON.BAS and the ATR8000 Monitor	64
G. Using More Than Two Drives With ATARI DOS	70
2. OS/A+ 4.1	72
A. Booting OS/A+ 4.1	72
B. Using ATARI 810 Drives With OS/A+ 4.1	73
3. ATR8000 System ROM	74
A. ATR8000 User Accessible Monitor Routines and Variables	74
1. ATR8000 Subroutine Entry Points	74
2. Disk I/O Control Block Format	76
B. ATR8000 Memory Map	77
C. Global Variables	78
IV. Expanding the ATR8000	80
1. Converting to 64K	80
2. Adding Drives, a Printer, or a Modem	80
3. Adding CO-POWER-88™	81
V. Warranty, Software License and Service Policy	82

Diagrams

	<u>Page</u>
1. The ATR8000 (Back View)	8
2. The Ports of the ATR8000 (Back View)	10
3. RS-232 Serial Printer Cable	13
4. Standard Centronics Parallel Printer Cable	14
5. Nonstandard Centronics Parallel Printer Cable	14
6. Standard Drive Cable	15
7. RS-232 Port Pin Order	16
8. FLOPPY DISK Port Pin Order	17
9. PRINTER Port Pin Order	18
10. PRINTER PORT Pin Order, Centronics	19
11. COMPUTER IN and PERIPHERAL OUT Ports Pin Order	20
12. The Percom ATARI Controller Drive	23
13. Drive Numbering #1	29
14. Drive Numbering #2	29
15. 5 1/4" Tandons and Some Percoms	30
16. Aerocomp, MPI and Some Percom Drives	31
17. Shugart 400s	31
18. Shugart 460s	32
19. Configuring an ATARI 810 Drive	32
20. Front View of the Model I Drive's Board	33
A. Back View of the Model I's Board	34
B. The DPDT Before Connection	35
C. The DPDT Switch After Connection	36
21. Cable Binding for the Television	39
22. Hardware Connection Diagrams	
A. The Ports of the ATR8000 (Back View)	40
B. Making the Connections (for II.6.A.)	40

C. Making the Connections (for II.6.B.)	44
D. Making the Connections (for II.6.C1.)	45
E. Making the Connections (for II.6.C2.)	46
F. Making the Connections (for II.6.C3.)	47
23. Jumper Option Locations	48
24. 16k or 64k — J1, J2, J3, J4, J5, J6, J8	49
25. ATARI or RS-232 Terminal — J7, J10	50
26. 2 or 4k Operating ROM — J9	50
27. Printer Port Disabling — J11	51
28. RS-232 Configuring — J12	51
A. Configuration of J12 to Connect an Epson Serial Printer (the default)	52
B. Configuration of J12 to Connect a RS-232 Terminal to the RS-232 Port to Communicate with the ATARI	52
C. Configuration of J12 to Connect a D.C. Hayes Smart Modem to the RS-232 Port	52
29. ATR8000 Monitor Commands	64

Photos

	<u>Page</u>
#1 Using the Ferrite Core	39
#2 Connecting the ATR8000 to the ATARI 800/400	41
#3 Connecting the Standard Drive Cable to a 5 1/4" Tandon Drive	42
#4 Connecting an 8" Drive Adapter Board to an 8" Tandon Thinline Drive	42
#5 Plugging the 8" Adapter Board onto the Standard Drive Cable	43
#6 Connecting the Standard Drive Cable to the ATR8000	43

I. Introduction

Congratulations, you have purchased the most expandable, versatile disk interface available for your ATARI 800/400. The ATR8000 allows you to delve beyond the ATARI microcomputer world into another that offers nearly countless hardware and software options.

Serial or parallel printers can be connected to the ports of the ATR8000. You can choose from medium-speed, economical dot matrix printers to the faster, slightly higher-priced, dot addressable dot matrix printers. OR you can get the quality and printing versatility of a more expensive daisy wheel printer.

For program storage, single, double or quad density, single or double-sided, 5 1/4" or 8" disk drives can be connected to the ATR8000. You're not limited to one type or size of drive because they can be intermixed!

Single density ATARI DOS and double density OS/A+ 4.1 both run on the ATR8000. OS/A+ 4.1 is a double density DOS that runs faster than ATARI DOS and stores twice as much data on a disk. Section III contains supplemental information to each of these DOS's operating manuals. The ATARI DOS portion of Section III has a serial printer driver listing. This driver is for ATARI DOS and OS/A+ printing. An ATARI DOS emulation of the ATR8000 monitor and monitor instructions are also included.

The 64k ATR8000 includes double density CP/M 2.2, complete with the standard CP/M manual. SWP furnishes an additional ATR8000 CP/M Supplement that describes SWP CP/M utility programs. This supplement also contains information for programmers.

To connect the ATR8000, the ATARI 800/400, disk drives and any peripherals you have, follow the basic connection procedure in this section. For more specific connection information, consult Section II.

Detailed information on the construction of the cables used with the ATR8000 system is in Section II.1. Some peripherals, like those connected to the RS-232 Port, require configuring of jumper options on the ATR8000 circuit board. These options are clearly outlined in Section II.7.

Section II also details how to connect an RS-232 terminal to the 64k ATR8000. Section IV explains how to expand the ATR8000. You'll find the system easy to add to so you can build up a computer system that will meet your expanding needs. The last section, Section V, contains warranty information and the software license. Complete the enclosed warranty card and return it to us within 10 days to ensure that your ATR8000 is under warranty.

Thoroughly read this manual and carefully follow the instructions contained within to connect the ATR8000 and to start the journey into a broader-based microcomputer world. Because the ATR8000 is immensely versatile, connections can become involved. Use the Table of Contents to locate the specific sections that will help you understand your ATR8000 system.

Happy computing!

I.1 The ATR8000 System:

ATR8000 - the basic unit. It is a 4MHz, Z80 processor available in two models: 16k or 64k RAM. (The 64k version includes CP/M 2.2.) The ATR8000 has a COMPUTER IN port for connecting the ATARI 800/400 or a RS-232 terminal, a PERIPHERAL OUT port for connecting the ATARI Daisy Chain Cable, a parallel PRINTER port, a FLOPPY DISK serial port for connecting disk drives, and an RS-232 port. A cable for connecting the ATR8000 to the ATARI 800/400 or to a terminal is included.

DIAGRAM 1: The ATR8000 (Back View)

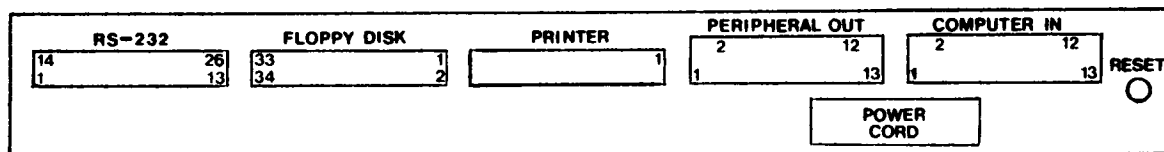

64k UPGRADE - upgrades the 16k ATR8000 to 64k RAM. CP/M configured for the ATR8000 is included, along with a CP/M manual and the ATR8000 CP/M Supplement. SWP supplies several double density system programs for CP/M users. CP/M is available on both 5 1/4" and 8" disks.

OS/A+ 4.1 - a double density DOS for ATARI from Optimized Systems Software, Inc. This DOS is faster than ATARI DOS and stores twice as much data on a disk. A separate manual detailing the use of this DOS is included. This DOS is available on both 5 1/4" and 8" disks.

DISK DRIVES - high-quality 5 1/4" drives with power supplies are available in one and two-drive custom enclosures. Two 8" Tandon Thinline drives with power supplies are available in a custom, ventilated enclosure.

PRINTER CABLES - we manufacture both serial and parallel printer cables to connect a printer to the ATR8000.

STANDARD DRIVE CABLES - daisy chain drive cables that plug into the FLOPPY DISK Port. Available in 2-connector and 4-connector styles.

8" ADAPTERS - used to connect an 8" drive to the Standard Drive Cable. These special adapters connect between the 50-pin edge connector of an 8" drive and the 34-conductor drive cable ribbon. This allows both 5 1/4" and 8" drives to be connected on the same cable, so both can be run at the same time.

I.2 Power Requirements

The ATR8000 and all SWP peripherals requiring power plug into regular wall sockets (115-120 volts AC). The ATR8000 has a built-in MOV (Metal Oxide Varistor) to suppress power surges and to keep voltage at a safe level to protect sensitive circuit components.

I.3. Connecting the ATR8000 System: The Basics

This section describes the basic ATR8000 connection procedure. Section II contains more specific connection information. If you have any questions about the basic procedure, refer to the Table of Contents to find where the specific information you need is in Section II.

I.3.A. Materials Needed:

You will need the following to connect the ATR8000 system:

- An ATR8000-ATARI cable if connecting to an ATARI or an ATR8000-Terminal cable if connecting to an RS-232 terminal.
- If connecting any ATARI 810 drives, an ATARI Daisy Chain Cable.
- A Standard Drive Cable.
- One 8" Drive Adapter Board for each 8" drive.
- If you have a parallel printer, a parallel printer cable. If you have a serial printer, a serial printer cable.
- If internal drive numbering will be necessary, a screwdriver for removing the drive cover.
- If you are using a television for a monitor, a ferrite core (included with the ATR8000).

I.3.B. Disk Drive Basics

#1 If you have more than one disk drive, decide what each drive's number will be (1 - 4). D1 must be used to boot.

HINTS: ATARI 810 drives are best designated as the higher drive numbers.
An ATARI 810 can boot ATARI DOS.
A standard 5 1/4" drive can boot ATARI DOS, OS/A+ and CP/M.
An 8" drive can boot OS/A+ and CP/M. It can also boot ATARI DOS if the DOS is copied to an 8" disk. (See Section III.)

#2 Each drive needs to be configured. Standard drives are configured internally for drive number. Numbers for ATARI 810 drives are set by positioning the switches at the back of the drive. For each standard drive, set the following:

- one drive select. Drive selects are labeled as DS 1-4 or DS 0-3 on a drive's circuit board.
- head load with motor on.

#3 The last connector on the standard drive cable must have a drive connected

to it. If this drive is a 5 1/4" drive, it must have a terminating resistor pack in it. If this drive is an 8" drive it must have the terminating resistors set.

I.3.C. Printer Basics

- #1 A parallel printer connects to the PRINTER Port. There is a parallel printer driver in the ATR8000 ROM for ATARI DOS and OS/A+ printing.
- #2 A serial printer connects to the RS-232 Port. Set the printer for no parity, 8 bits and 1200, 2400, 4800, or 9600 baud. A serial printer driver for ATARI DOS and OS/A+ printing is listed in Section III.
- #3 An 820/822 printer connects to the ATARI Daisy Chain Cable. [To print jumper J11 on the ATR8000 circuit board or run PRINTOFF.BAS.]
- #4 If an ATARI 850 is connected, connect the serial or parallel printer to the 850. To print, activate J11 or run PRINTOFF.BAS.

For CP/M printing, the printer must be directly connected to the ATR8000.

I.3.D. ATARI 850 Basics

- #1 An ATARI 850 connects between the ATARI and COMPUTER IN.
- #2 If the 850 is connected, the printer must be connected to the 850 rather than directly to the ATR8000.
- #3 The 850 cannot be connected when the system is running CP/M.

I.3.E. Making the Connections

When connecting cables, it is important that Pin 1 on each cable is connected to Pin 1 of the corresponding port. Pin 1 on most cables is marked on the inside of the connectors. Some cables have a contrasting color on one edge of the cable, denoting that it leads to Pin 1.

The following Diagram shows Pin 1 locations for each of the ATR8000's ports.

DIAGRAM 2: The Ports of the ATR8000 (Back View)

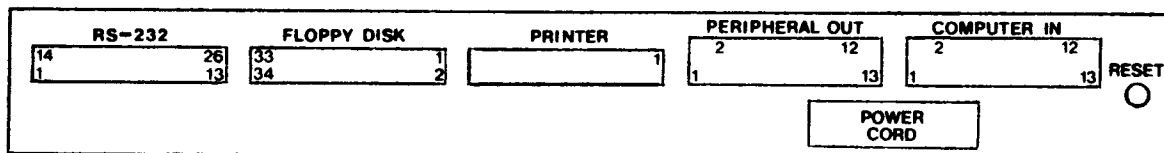

Connections:

- #1 This step is only for those who are using an ATARI 800/400 and a television as a monitor.

Unplug the cable that connects the ATARI to the television. On the television end of the cable, loop the cable through the ferrite core five times. Replug the cable to the television.

- #2 ATARI users: Connect the ATR8000 to the ATARI with the ATR8000-ATARI cable. (The cable that has an "ATARI" connector at each end.)

RS-232 terminal users: Connect the ATR8000 to the RS-232 terminal with the ATR8000-Terminal cable. Before powering the system, refer to Section II.7.B to properly jumper the ATR8000.

- #3 Connect the Standard Drive Cable to the standard drives. Plug an 8" Drive Adapter Board onto each 8" drive before connecting 8" drives to the cable. The last connector on this cable must have a drive attached to it and this drive must have the terminating resistors set.

- #4 Set each drive for drive number and head load with motor on.

- #5 Connect the Standard Drive Cable to the FLOPPY DISK Port.

- #6 Connect any ATARI 810s to the ATARI Daisy Chain Cable. Connect this cable to PERIPHERAL OUT. Set each ATARI 810 for drive number.

- #7 If you are using an ATARI 850: Connect the 850 between the ATARI and COMPUTER IN. To print while the 850 is connected, connect the printer to the 850, not to the PRINTER Port or the RS-232 Port.

If you are not using an ATARI 850: Connect a parallel printer to the PRINTER Port using a parallel printer cable. Connect a serial printer to the RS-232 Port using a serial printer cable. [The RS-232 port is default configured for an Epson serial printer. More information is in Section II.7.]

- #8 A modem can be connected to the RS-232 port. It can also be connected to an 850.

II. The Connection in Detail

Each of the following subsections contains specific information about the components of the ATR8000 system. Use the Table of Contents to find information about your system. If you do not thoroughly understand any information pertaining to your system, reread and study the information until you have a working knowledge of the stipulations. (For unresolvable difficulties, consult your dealer.)

Unplug all of the components before connecting and configuring the ATR8000. If a component is turned off but is still plugged into an electrical socket, you can be shocked.

For all connections it is important that the cables are correctly interfaced to the ATR8000. Subsection 1 contains diagrams showing the construction of each type of cable that connects to the ATR8000. Pin 1 on each cable is marked. (On some types of cables, Pin 1 is denoted by a colored wire on an outside edge of the cable.)

Subsection 2 contains ATR8000 port information. The order of each port's pins is shown along with a listing of the pin signals. Pin 1 of the port must be connected to Pin 1 of the interfacing cable.

Specific data about disk drives, modems and printers is discussed in Subsection 3. This information **MUST** be considered before making any connections. Drive configuring is done in Subsection 4. Each drive must have a unique and valid number. Subsection 5 tells you how to avoid radio frequency interference.

Detailed instructions for connecting the ATR8000 system are in Subsection 6. These instructions include step-by-step connection photos. After the cables have been connected, the ATR8000's jumper options need to be considered. These options and their settings are described in Subsection 7.

Subsection 8 explains the optional connection of an RS-232 serial terminal to the 64k ATR8000 (in place of the ATARI). The 64k ATR8000 and an RS-232 terminal can be used for CP/M operation. [The terminal must be 9600 baud, odd parity and 7 bits.]

II.1. Cable Specifications

This section contains diagrams that detail the construction of the cables used with the ATR8000 system. If you make your own cables, or purchase cables from a source other than SWP, make sure they are similarly constructed.

II.1.A. & DIAGRAM 3: RS-232 Serial Printer Cable

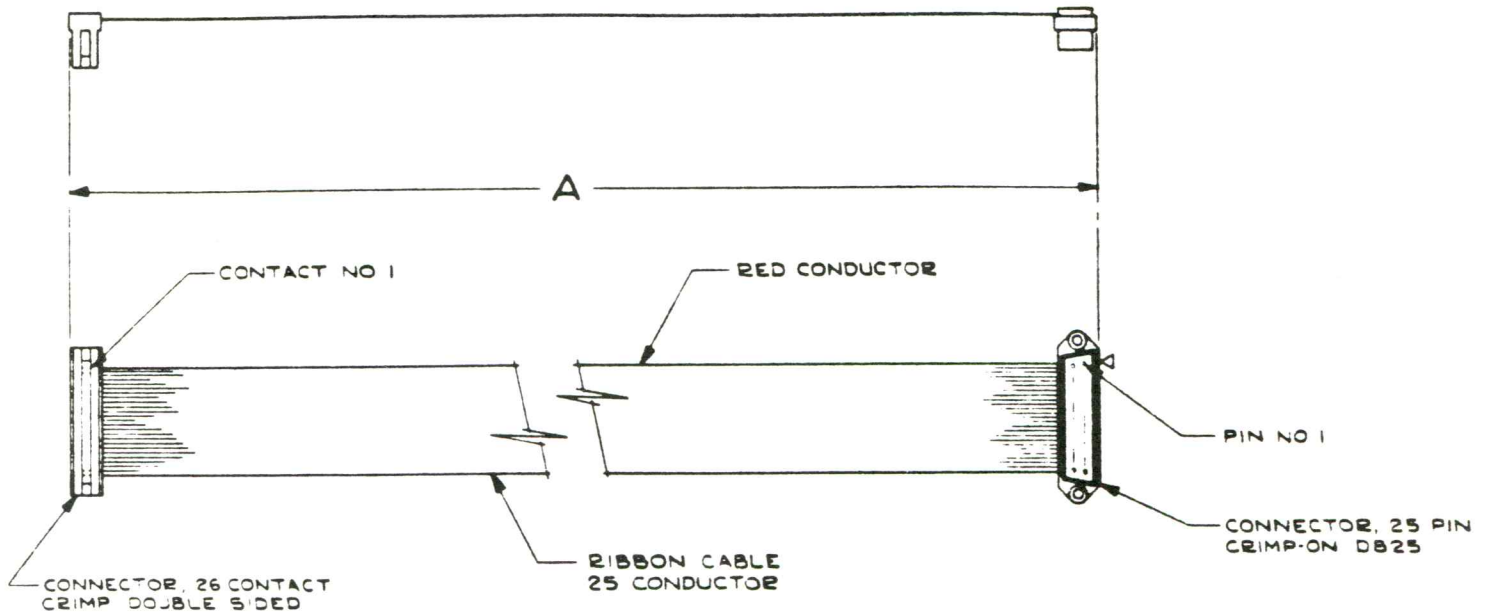

II.1.B. & DIAGRAM 4: Standard Centronics Parallel Printer Cable

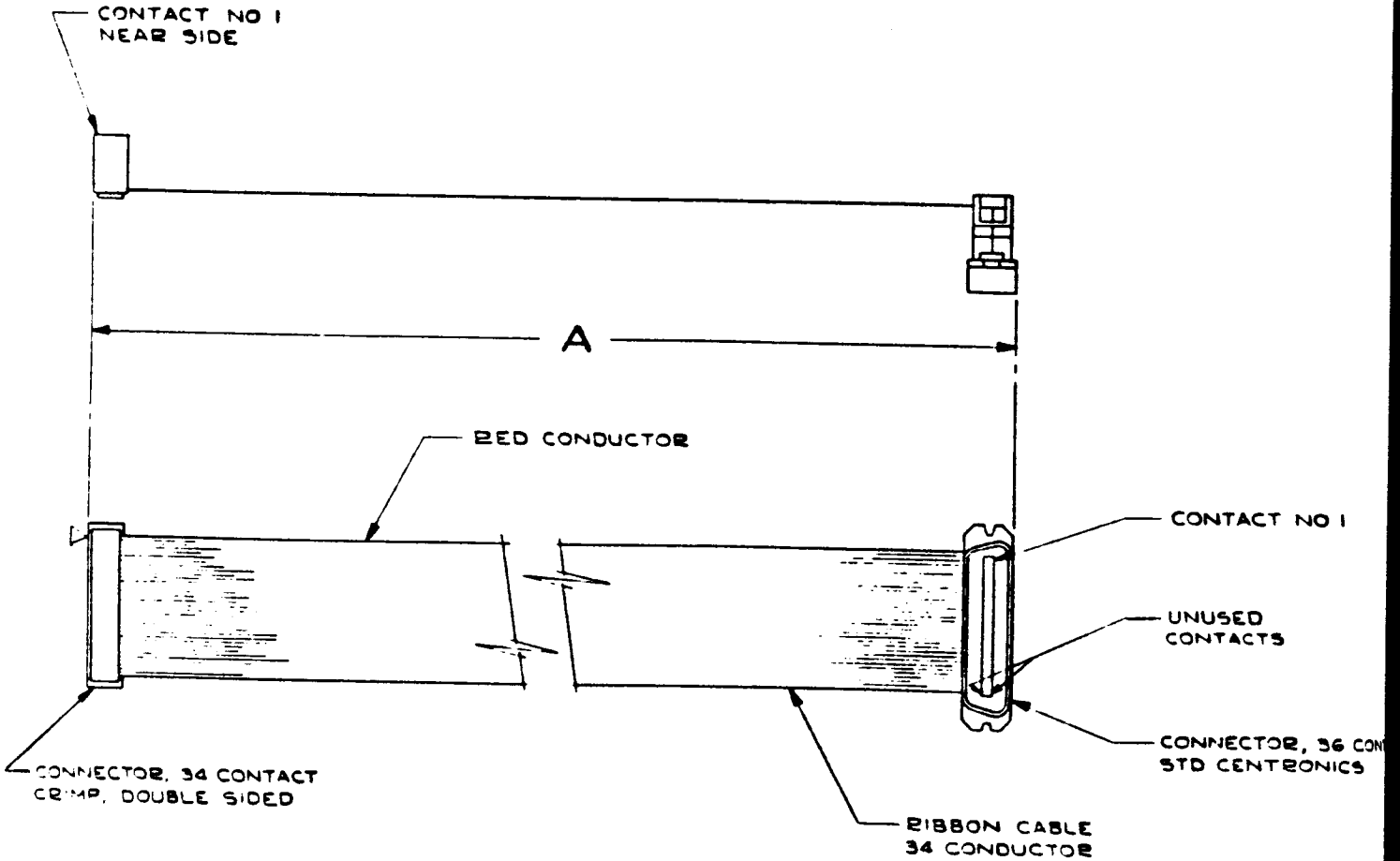

II.1.C. & DIAGRAM 5: Nonstandard Centronics Parallel Printer Cable

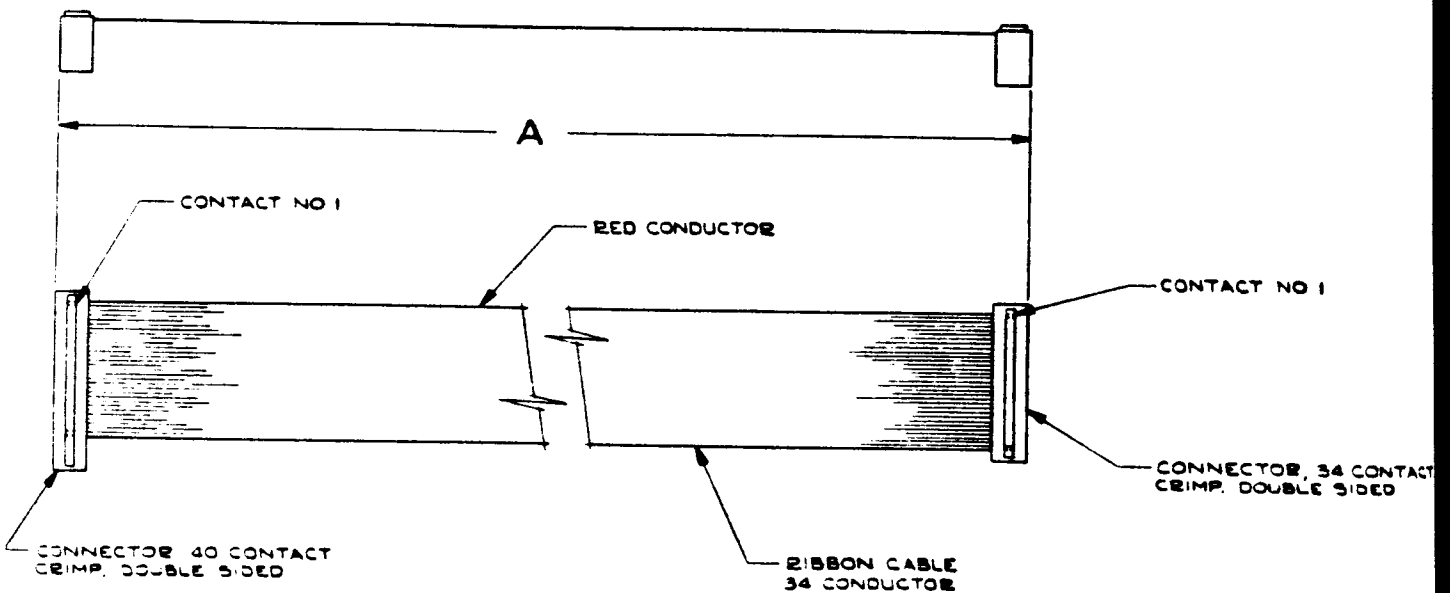

II.1.D & DIAGRAM 6: Standard Drive Cable (4-connector cable shown)

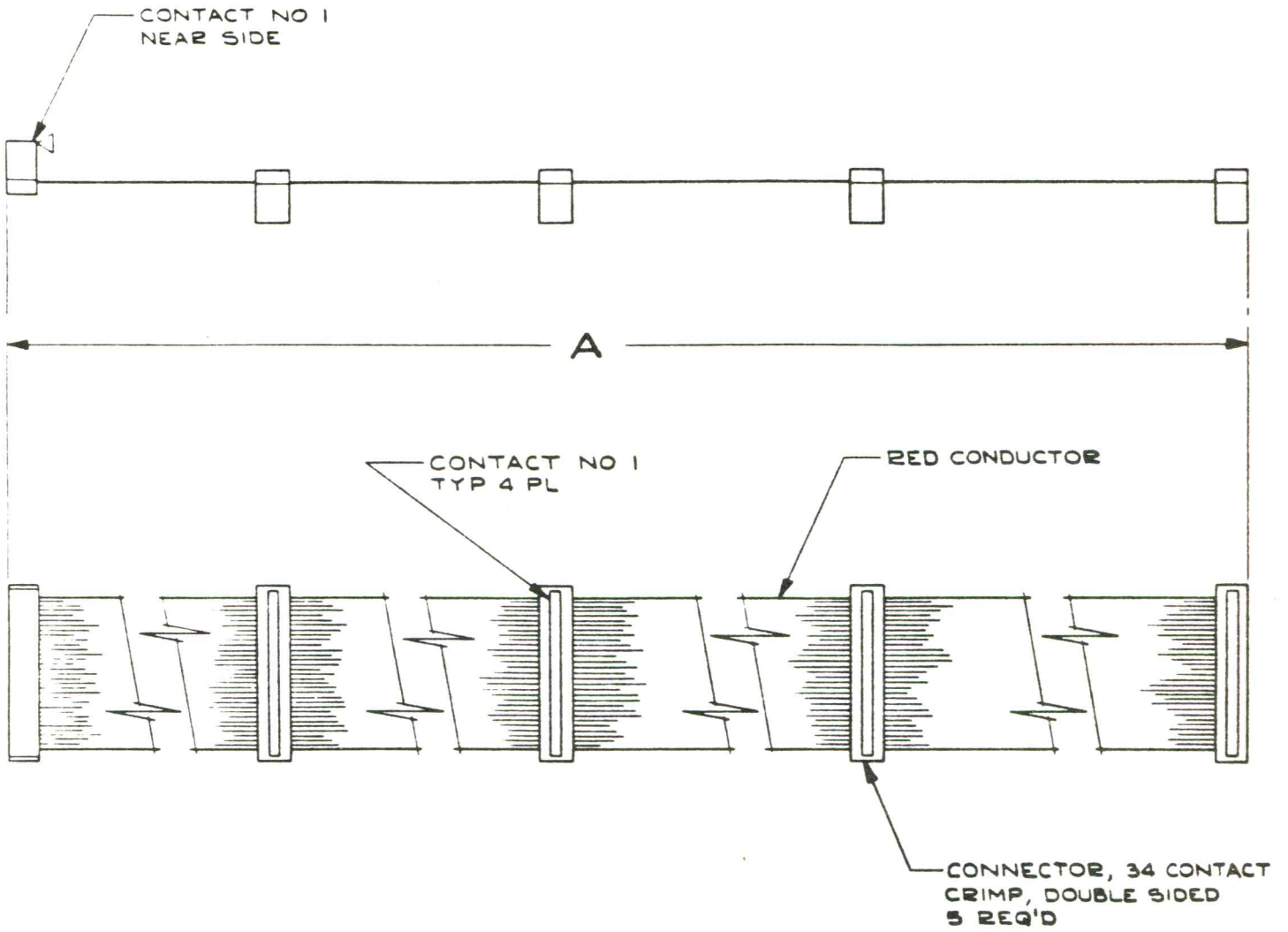

II.2 ATR8000 Port Specifications

This subsection lists the pin information for each of the ATR8000's ports. Supplementary diagrams show the order of the pin numbers on each port's edge connector.

II.2.A. RS-232 Port

RS-232 Port Pin Information

1. N.C. (not connected)	14. N.C.
2. Transmit Data	15. N.C.
3. Receive Data	16. N.C.
4. Request to Send	17. N.C.
5. Clear to Send	18. N.C.
6. Data Set Ready	19. N.C.
7. Signal Ground	20. DTR
8. Carrier Detect	21. N.C.
9. N.C.	22. Ring Indicator
10. N.C.	23. N.C.
11. Reverse Channel	24. N.C.
12. N.C.	25. N.C.
13. N.C.	26. N.C.

When looking at the back of the ATR8000, the RS-232 Port pins are in the order shown below. When interfacing to this port, make sure that Pin 1 on the RS-232 cable is connected to Pin 1 of the port.

DIAGRAM 7: RS-232 Port Pin Order

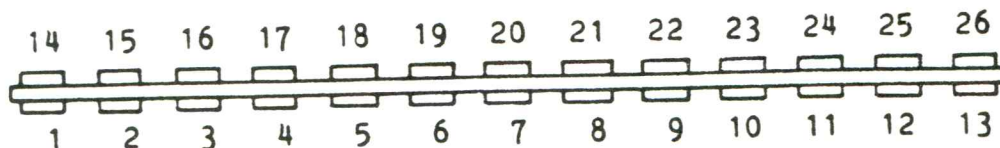

II.2.B. FLOPPY DISK Port

FLOPPY DISK Port Pin Information

1. Ground	18. Direction Select
2. N.C. (not connected)	19. Ground
3. Ground	20. Step
4. N.C.	21. Ground
5. Ground	22. Write Data
6. Drive Sel 4	23. Ground
7. Ground	24. Write Gate
8. Index	25. Ground
9. Ground	26. Track 00
10. Drive Sel 1	27. Ground
11. Ground	28. Write Protect
12. Drive Sel 2	29. Ground
13. Ground	30. Read Data
14. Drive Sel 3	31. Ground
15. Ground	32. Side Sel
16. Motor On	33. Ground
17. Ground	34. N.C.

When looking at the back of the ATR8000, the FLOPPY DISK Port pin numbers are as shown below. When connecting a disk drive cable to the port, make sure that Pin 1 on the cable matches Pin 1 on the port.

DIAGRAM 8: FLOPPY DISK Port Pin Order

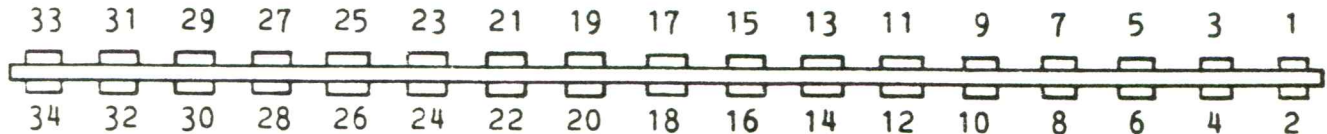

II.2.C. PRINTER Port

The following information is for a printer cable that is constructed from standard 34-conductor ribbon cable and a standard 34-pin connector. Pin information for a standard Centronics cable that uses a Centronics D connector is on the following page.

PRINTER Port Pin Information

1. Strobe	18. Ground
2. Ground	19. D3 In
3. D0 Out (Data 0)	20. Ground
4. Ground	21. D7 In
5. D1 Out	22. Ground
6. Ground	23. D6 In
7. D2 Out	24. Ground
8. Ground	25. D5 In
9. D3 Out	26. N.C.
10. Ground	27. Ground
11. D4 Out	28. D4 In
12. Ground	29. D2 In
13. D5 Out	30. D1 In
14. N.C. (not connected)	31. N.C.
15. D6 Out	32. D0 In
16. Ground	33. N.C.
17. D7 Out	34. N.C.

When looking at the back of the ATR8000 at the PRINTER Port, the pins are numbered as below. Make sure that you match Pin 1 on the Port with Pin 1 on the cable used to interface into the PRINTER Port. (This is a parallel port.)

DIAGRAM 9: PRINTER Port Pin Order

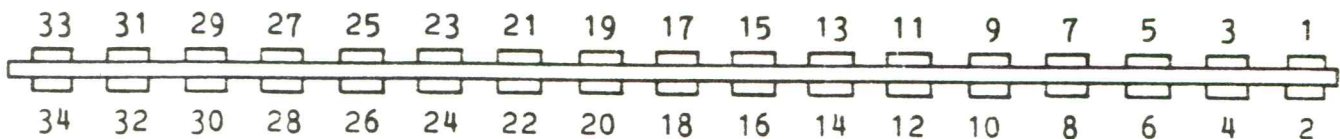

PRINTER Port Pin Information for a Centronics Cable

1. Strobe	19. Ground
2. D0 Out (Data 0)	20. Ground
3. D1 Out	21. Ground
4. D2 Out	22. Ground
5. D3 Out	23. Ground
6. D4 Out	24. Ground
7. D5 Out	25. Ground
8. D6 Out	26. Ground
9. D7 Out	27. Ground
10. D3 In	28. Ground
11. D7 In, Busy	29. Ground
12. D6 In	30. Ground
13. D5 In	31. N.C.
14. N.C.	32. D4 In
15. D2 In	33. D1 In
16. N.C.	34. D0 In
17. N.C.	35. N.C.
18. *	36. *

* These two pins are not used and are not on the ATR8000 PRINTER Port's edge connector. When plugging a 36-pin connector on this edge connector, align Pin 1s.

[A Centronics printer uses eight data outs (D0 - D7), but only four data ins (D0 - D3). The other data ins are included to make the PRINTER Port a full parallel port.]

A Centronics D connector orders pins in a different sequence than those listed in DIAGRAM 9. For this connector, use the following pin order:

DIAGRAM 10: PRINTER Port Pin Order, Centronics

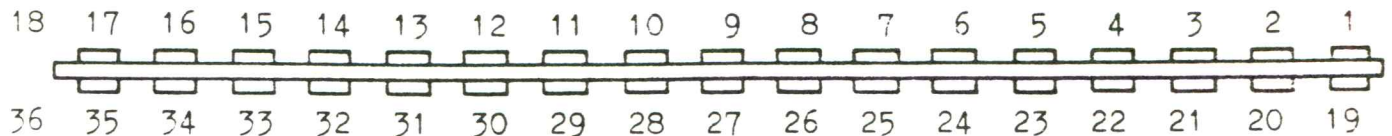

II.2.D. The COMPUTER IN and PERIPHERAL OUT Ports

The COMPUTER IN and PERIPHERAL OUT Ports both have "ATARI" connectors. They are used to interface the ATARI 800/400 and any ATARI peripherals to the ATR8000. These two ports are internally connected. Technically, they are one port with a duplex connector.

Because the two ports are interconnected, it doesn't matter which port is used to connect an ATARI and which port is used for ATARI peripherals. We have labeled them to eliminate confusion for computer novices.

COMPUTER IN and PERIPHERAL OUT Pin Information

- | | |
|------------------|------------------|
| 1. Clock Input | 8. Motor Control |
| 2. Clock Output | 9. Proceed |
| * 3. Data Input | * 10. +5/Ready |
| * 4. Ground | 11. Audio Input |
| * 5. Data Output | 12. +12 Volts |
| * 6. Ground | 13. Interrupt |
| * 7. Command | |

* These pins are connected in the ATR8000 cables.

When looking at the back of the ATR8000, the order of the pins for these ports is as shown below.

DIAGRAM 11: PERIPHERAL OUT and COMPUTER IN Ports Pin Order

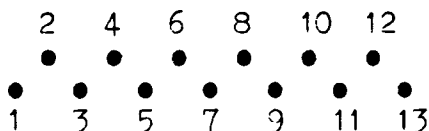

II.3. Peripherals

The ATR8000 system is extremely versatile; it interfaces with nearly all peripherals in the microcomputer market. This means you can connect various types of disk drives, printers and modems to the system. Depending on what you have acquired, connecting your peripherals could be complex.

This subsection explains stipulations for connecting some peripherals, including the affect of certain peripherals on other components in the system. Carefully read this data. If several of the following considerations apply to your equipment, make notes to refer to during the connection process.

II.3.A. Disk Drives

There are a few basic rules to follow for disk drives. All of these rules are explained in greater detail later. These are:

RULES FOR DISK DRIVES

1) BOOTING AND OPERATING:

- D1 is the drive that OS/A+ or ATARI DOS is booted from. This drive is called A when the system is running CP/M.
- To boot ATARI DOS, D1 can be either an ATARI 810 or a standard disk drive. Operating under ATARI DOS, the system's drives can be either 810s or standard drives (or a mixture).
- To run OS/A+, the system must be booted from a standard disk drive. Operating under OS/A+, the system's drives can be a mixture of ATARI 810s and standard drives. [For OS/A+ 4.1, a disk in an 810 drive can only be accessed after ADOS is run. An 810 drive is then referred to as "An" as opposed to "Dn." Disks in 810 drives can be read and written to, but not formatted.]
- To run CP/M, the system must be booted from and run on standard disk drives.

2) NUMBERING:

- Each drive interfaced to the ATR8000 system must have a unique and valid drive number (1-4 or A-D). (Explained in Section II.4.)

3) CONNECTING:

- ATARI 810 drives are connected to the PERIPHERAL OUT Port. Standard drives are connected to the FLOPPY DISK Port.
- When using the Standard Drive Cable to connect drives to the FLOPPY DISK Port, the last connector on the cable must have a drive plugged into it. This drive must have the terminating resistors set. (Terminating resistors are explained in Section II.4.)

The ATR8000 runs all standard 5 1/4" and 8" disk drives. ATARI 810 and Percom drives can also be used with certain limitations. Disk drive sizes (5 1/4" or 8"), densities (single, double or quad) and type (single or double-sided) can be intermixed. All drives must have their own power supplies.

II.3.A1. ATARI 810 Drives

ATARI 810 disk drives are nonstandard drives that are only capable of single density operation. These drives can be used with the ATR8000 to run single density ATARI DOS. They can also be used with single density OS/A+ 2.0. ATARI 810 drives can be read from or written to with OS/A+ 4.1, but they cannot be formatted under OS/A+ 4.1. [To use an 810 with OS/A+ 4.1, run ADOS. Then log onto the 810 by typing "An" instead of "Dn."] **ATARI 810 drives cannot be used for CP/M operation.**

ATARI 810 drives connect to the ATR8000 on the ATARI Daisy Chain Cable that connects to the PERIPHERAL OUT Port. The ATR8000 runs up to four drives of mixed definition. So, if one ATARI 810 drive is connected, three standard drives can also be connected.

The drive designated as Drive 1 is the drive that boots the operating system. A standard 5 1/4" drive can boot all three DOSes (ATARI, OS/A+, and CP/M), whereas an ATARI 810 drive can only boot ATARI DOS. If you have both standard drives and 810s, drive renumbering can be avoided by designating any standard drives as the lower drive numbers and any 810s as the higher drive numbers.

If you have an ATARI 810 drive and 8" drives (but no 5 1/4" drives), being able to boot all three DOSes from the same drive becomes more complex. For the more information, refer to Section II.3.A4.

II.3.A2. Percom Drives

ATARI Controller Drives:

A Percom ATARI controller drive can be used with the ATR8000 with some limitations. For ATARI DOS or OS/A+, it can be connected (with no alterations) to the ATARI Daisy Chain Cable that connects to the PERIPHERAL OUT Port of the ATR8000. OR, it can be used as standard disk drive if the Percom ATARI controller board is disconnected and the drive's controller board is connected to the Standard Drive Cable (which connects to the FLOPPY DISK Port of the ATR8000). To run CP/M, the Percom ATARI controller board must be disconnected.

Disconnecting the Percom Controller:

The Percom ATARI controller drive is shown in DIAGRAM 12 on the next page. To disconnect the controller card, first remove the screws from the Percom drive enclosure and take the cover off.

Notice that when looking at the front of the drive (where the RFD light is to the right side of the drive), the drive's controller board is on the left side of the drive (it is roughly 5" by 5") and the Percom ATARI controller board is

on the right side of the drive (it is a larger card, roughly 5" by 8").

An internal cable connects the Percom controller board to the drive's controller board, then this cable connects from the drive's controller board to the connector on the back of the drive enclosure.

To use the Percom ATARI controller drive as a standard drive: 1) Unplug the internal cable from the drive's controller board; 2) Bring one of the Standard Drive Cable's connectors into the enclosure and plug this connector to the edge connector on the drive's controller board (matching Pin 1s); 3) Thread the cable out the back of the drive. Do not replace the drive's cover until the drive is internally configured for drive number in the next subsection.

DIAGRAM 12: The Percom ATARI Controller Drive

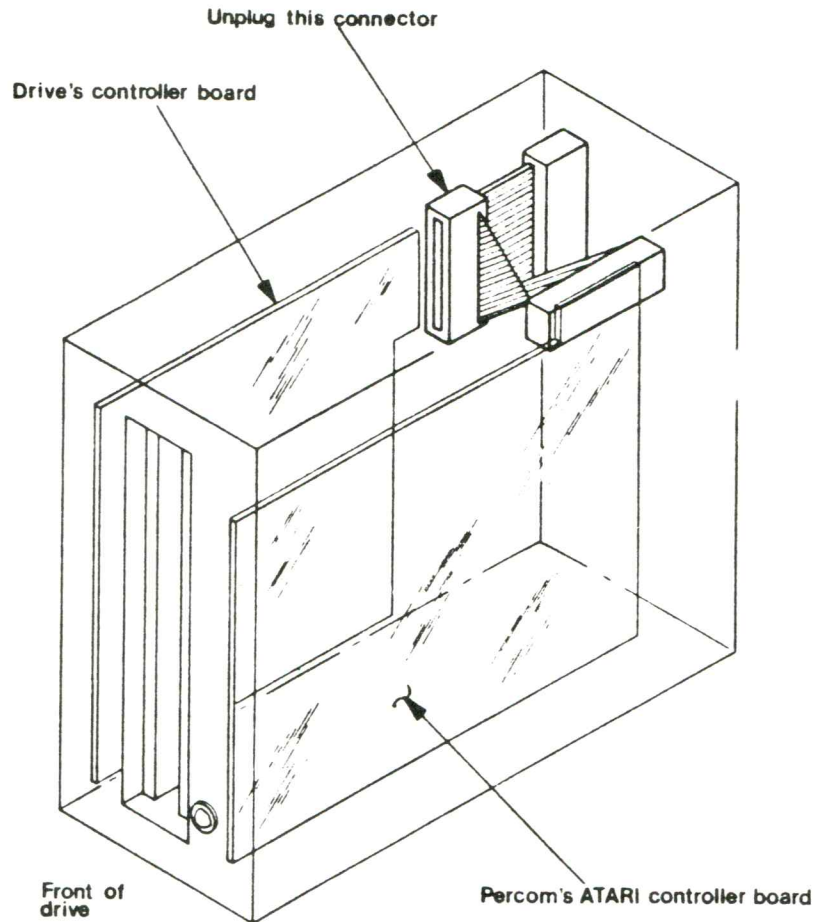

Percom ATARI Add-on Drives:

Percom ATARI add-on drives are standard disk drives. They have an internal cable that connects the edge connector of the drive's controller board to the pin connector on the outer edge of the drive. Remove the drive's cover and disconnect this cable. Plug one of the Standard Drive Cable's connectors onto the edge connector of the drive's controller board. Leave the drive's cover off until the drive is configured for drive number.

II.3.A3. Using All 5 1/4" Drives

Connecting standard 5 1/4" drives with or without ATARI 810 drives is fairly straightforward. An ATARI 810 drive can only boot single density ATARI DOS, whereas a standard 5 1/4" drive can boot ATARI DOS, OS/A+ and CP/M. Therefore, when assigning drive numbers for a system using these two types of drives, it is best to set the standard drives as the lower drive numbers and ATARI drives as the higher drive numbers. (Remember that the system is booted from Drive 1.)

Due to different interfaces, ATARI 810 drives and standard drives are connected on different cables. ATARI 810 drives are connected to the ATARI Daisy Chain Cable which is connected to the PERIPHERAL OUT Port of the ATR8000. Standard drives are connected to the Standard Drive Cable which is connected to the FLOPPY DISK Port of the ATR8000.

You must be careful to assign a unique drive number to each drive. For example, if standard drives are designated as Drive 1 and Drive 2, an 810 drive could be either Drive 3 or Drive 4. (The Standard Drive Cable must have a drive connected on the connector that is furthest from the ATR8000 port connector. This drive can be configured to be any drive number.)

II.3.A4. 8" Drives

Using Only 8" Drives:

8" drives are connected to the ATR8000 on the Standard Drive Cable which connects to the FLOPPY DISK Port. An 8" drive has a 50-pin connector and the ATR8000's FLOPPY DISK Port interfaces with a 34-conductor ribbon drive cable. An 8" drive is connected to this cable by using the SWP 8" Drive Adapter Board. This adapter plugs onto the drive's 50-pin connector and properly connects the signals to the 34-conductor ribbon drive cable.

OS/A+ and CP/M are available on 8" disks. ATARI DOS can be copied from a 5 1/4" drive to an 8" drive. This limits the 8" disk's storage capacity to 720 sectors, the capacity of a 5 1/4" disk. (A single density 8" disk has 2002 sectors). See Section III for more details.

Using ATARI 810s and 8" Drives:

ATARI 810 drives are connected to the PERIPHERAL OUT Port of the ATR8000 on the ATARI Daisy Chain Cable. Standard 8" drives are connected to the FLOPPY

DISK Port of the ATR8000 using the Standard Drive Cable and one 8" adapter board for each 8" drive.

Using ATARI 810 drives and standard 8" drives requires a preconnecting decision. An ATARI 810 will not boot OS/A+ or CP/M and a standard 8" drive cannot boot a 5 1/4" ATARI DOS disk. There are two options:

- 1) An ATARI 810 can be set as Drive 1 to boot ATARI DOS, with the 8" drives set as higher drive numbers. To boot OS/A+ or CP/M the drives would have to be renumbered so that an 8" drive is Drive 1. (Drives are set for drive number internally. See Section II.4 for details.)
- 2) Initially an ATARI 810 can be set as Drive 1 and an 8" drive set as Drive 2. Then ATARI DOS can be copied to an 8" disk (instructions are in Section III).

LIMITATION: This does limit the use of the 8" drive the DOS is run from. ATARI DOS formats by sectors. An 8" disk has 2002 sectors (single density), whereas a 5 1/4" disk has 720. ATARI DOS running on an 8" disk will only use the first 720 sectors of the disk. Although ATARI DOS on an 8" disk doesn't give full access to the disk, it does eliminate drive renumbering when you switch DOSes.

After the ATARI DOS is transferred to an 8" disk, renumber (and internally configure) the drives so that Drive 1 is an 8" drive.

To connect an 8" drive to the Standard Drive Cable, plug the 8" Drive Adapter Board's 50-pin connector to the edge card connector on the drive, with the adapter board's connector on the upper side of the adapter circuit board. Then plug a connector on the Standard Drive Cable to the 34-pin edge connector of the adapter board.

II.3.A4A. Using ATARI 810s, 5 1/4" and 8" Drives

Before continuing, read the above information on ATARI 810 drives and standard 8" drives. The considerations for connecting all three of types of drives become complex, so carefully read the following information.

To eliminate unnecessary drive renumbering, we suggest that all operating systems be on the same disk size (5 1/4" or 8"). This enables the same drive to boot all three DOSes.

If you have all three types of drives, a standard 5 1/4" drive is the best drive for running all three operating systems because it can boot both single and double density and it utilizes all available disk space on the disk in Drive 1. For users that only run OS/A+ and CP/M, an 8" drive is equally qualified to run both DOSes. Both are available on an 8" disk and both DOSes will use all available disk space.

ATARI DOS can be transferred to an 8" disk (with limitations explained in Section II.3.A4 and in the Software Section). So, an 8" drive could be Drive 1 for all DOSes.

If your DOSes are on different disk sizes, the drives will have to be renumbered to boot the different systems. Drive 1 must be used to boot.

II.3.B. Modems

Standard modems can be connected to the RS-232 Port of the ATR8000. To use a modem for ATARI DOS or OS/A+ operation you can also interface it to an ATARI 850. To use a modem for CP/M, the modem must be connected to the RS-232 port of the ATR8000. SWP/CP/M software includes MODEM.COM, a multifunction modem program for the ATR8000. To use a modem with the ATR8000 (or to connect any peripheral to the RS-232 Port), you must configure J12 on the circuit board of the ATR8000. This jumper option is explained in detail in Section II.7.D RS-232 Configuring.

II.3.B1. ATARI 830 Modems

The ATARI 830 modem can be used in two ways. It can be connected to the RS-232 Port of the ATR8000 and run using ATR8000 modem software, or it can be run through the ATARI 850 Interface Module. If it is connected to the 850, the 850 is connected between the ATARI and the COMPUTER IN Port of the ATR8000.

Using an 830 Modem through the 850 affects the printing operation of the ATR8000. The ATARI 850 Interface Module and the ATR8000 both respond to printer signals. To do ATARI DOS or OS/A+ printing when the 850 is interfaced to the ATR8000 system, the printer function of the ATR8000 must be disabled. This can be done by using jumper option J11 or by running PRINTOFF.BAS (PRINTOFF.BAS is in Section III; J11 is described in Section II.7.) When the 850 is connected, the printer must be connected to the 850. **An 850 cannot be interfaced during CP/M operation.**

In summary, these are the stipulations:

- 1) An 830 Modem used through the 850 interface can operate with ATARI DOS or OS/A+. The modem cannot be used for CP/M until it is disconnected from the 850 and directly connected to the ATR8000.
- 2) When using the 830 Modem and the 850, the printer must be connected to the 850 and the printer function of the ATR8000 must be disabled using PRINTOFF.BAS or by activating J11. Only 80 column printers will function -- the ATARI 820/822 printers will not interface with the 850. The printer will not print under CP/M until the printer is directly connected to the ATR8000 and the 850 is disconnected from the system.

II.3.B2. Modems for CP/M

Purchasers of the 64k ATR8000 receive MODEM.COM, a CP/M program for operating modems from the RS-232 Port of the ATR8000. This program from the CP/M user's group, has been rewritten specifically for the ATR8000. It is only for CP/M modem operation.

To run this modem, jumper option J12 on the ATR8000 circuit board must be properly configured. Instructions for doing this are in Section II.7.E.

II.3.C. Printers

The ATR8000's PRINTER Port is a parallel port. Serial printers are connected to the RS-232 Port. (J12 must be configured for any peripheral connected to the RS-232 Port; it is default configured for an Epson serial printer.) Certain printers can also be connected to the ATARI Daisy Chain Cable or to the ATARI 850 Interface Module.

II.3.C1. 40 Column Printers: an ATARI 820 or 822

ATARI 820/822 printers can be used for printing under ATARI DOS or OS/A+ when connected to the ATARI Daisy Chain Cable. Before printing, the printer function of the ATR8000 must be disabled by running PRINTOFF.BAS or by activating J11. (PRINTOFF.BAS is in Section III; J11 is described in Section II.7.)

ATARI 820/822 printers cannot be connected if an ATARI 850 Interface Module is connected to the system. A 40 column printer cannot be used for CP/M printing.

II.3.C2. 80 Column and 132 Column Printers if an ATARI 850 is not Interfaced to the System

A parallel 80 column or 132 column printer connects to the PRINTER Port of the ATR8000. A serial 80 column or 132 column printer connects to the RS-232 Port of the ATR8000 (and J12 is configured). Normal print commands for ATARI DOS, OS/A+ and CP/M all function. The ATR8000 ROM contains a parallel printer driver. A dtrline serial printer driver for ATARI DOS and OS/A+ printing is listed in Section III. Printer drivers for CP/M are explained in the ATR8000 CP/M Supplement.

II.3.C3. 80 Column and 132 Column Printers if an ATARI 850 is Interfaced to the System

If an ATARI 850 Interface Module is connected to the ATR8000 system, the printer must be connected to the 850 to print under ATARI DOS or OS/A+ and the ATR8000's printer function must be disabled by activating J11 or by running PRINTOFF.BAS. (PRINTOFF.BAS is in Section III; J11 is described in Section II.7.) The 850 must be disconnected to print under CP/M and the printer must be connected directly to the ATR8000.

II.3.D. The ATR8000's Ports and Possible Peripherals

Following is a summary of the types of peripherals that can be connected to each of the ATR8000's ports.

COMPUTER IN: This port interfaces to an ATARI 800/400. A standard RS-232 terminal can be connected to the 64k ATR8000 in place of the ATARI at this port by using an ATR8000-Terminal Cable. The terminal must be 9600 baud, odd parity and 7 bits. The terminal should be able to emulate ADM 3A protocol.

If an 850 is used, the ATARI 800/400 is connected to the 850 which is connected to COMPUTER IN.

PERIPHERAL OUT: This port interfaces to the ATARI Daisy Chain Cable. The ATARI Daisy Chain Cable connects to ATARI 810 drives and ATARI 820/822 printers.

Percom ATARI Controller Drives with the Percom controller intact are connected here.

PRINTER: This port is to interface a parallel printer to the ATR8000. A parallel printer will print after a normal print command is executed. The parallel printer driver for ATARI DOS and OS/A+ is in the ATR8000 ROM. CP/M printer drivers are explained in the ATR8000 CP/M Supplement.

FLOPPY DISK: This port runs up to four standard disk drives of mixed size (5 1/4" or 8"), density (single, double or quad) and type (single or double-sided). An 8" drive requires an 8" adapter board that connects between the drive's 50-pin connector and the 34-conductor ribbon Standard Drive Cable.

Percom ATARI Controller Drives that have had the controller disconnected are connected here.

RS-232: This port is for interfacing serial peripherals to the ATR8000. Jumper option J12 on the ATR8000 circuit board must be set to match the requirements of the serial device interfaced. J12 is default set for an Epson serial printer.

For all three DOSes, this port will run a serial printer. An ATARI DOS and OS/A+ serial printer driver is listed in Section III. CP/M printer drivers are explained in the ATR8000 CP/M Supplement.

This port will also run a modem. 64k ATR8000 purchasers receive MODEM.COM, a multifunction modem program for CP/M.

Under CP/M, this port can also be used to communicate with another terminal.

II.4. Internal Drive Configuring

This subsection tells how to internally configure drives that are connected to the ATR8000. Before turning the power on the ATR8000 system, first follow these instructions for "setting up" your disk drives. (You should have decided drive numbers in Subsection 3.)

RULES FOR DRIVE CONFIGURING:

- #1 The drive connected to the Standard Drive Cable's last connector must have the terminating resistors set. These resistors may be in a resistor pack or separately on the circuit board. No other drive on this cable should have the terminating resistors set.
- #2 Each drive must have a unique drive number. Drive number is selected by activating one of the drive selects.
- #3 Other jumper options, such as head load and multiplex, should be set according to your drive's specifications. Some drives are explained in the remainder of this section.

II.4.A. 5 1/4" Drives:

Before configuring your drives, select a cable connecting method. There are two ways to connect the Standard Drive Cable.

DIAGRAM 13: Drive Numbering #1

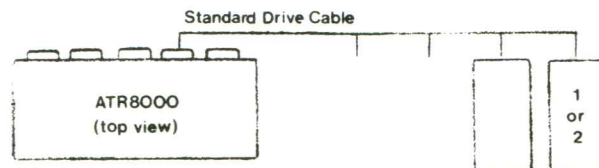

The drive on the last connector of the 4-connector cable could be set to be either Drive 1 or Drive 2. Select the numbering system (i.e., 1,2,3,4 or 4,3,2,1) that suits you. The cable can also be looped so that the last connector on the cable is connected to Drive 1 and the drive numbers are in ascending order:

DIAGRAM 14: Drive Numbering #2

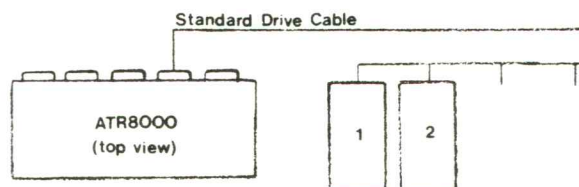

The connection and numbering method in Diagram 14 is the most common. Regardless of the numbering order you choose, the drive on the last connector must have the terminating resistor pack in it. (Drive 1 in DIAGRAM 14.)

Configuring 5 1/4" drives is simple. Jumper options for most 5 1/4" drives are grouped together, connected in a removable shunt. For each drive set one drive select and set the head load with motor on signal. If you have more than one drive on the cable, make sure that MX (multiplex) is open. The drive connected to the last connector on the drive cable must have a terminating resistor pack. Remove this pack from all other drives.

On most drives, the jumper options have a dip shunt connecting them. This is a "box" that has a plugged hole at each option, connecting signals from the incoming side of the box to the outgoing side. Punching out a hole (disconnecting the connection) disengages that option. A plug in the hole means that the option is active. You may want to remove this dip shunt and replace it with a dip switch shunt. This box will have switches that can be set to the left or to the right, turning an option on or off. This type of shunt makes it easier to renumber a drive.

II.4.A1. Configuring 5 1/4" Tandons and some Percom Drives

The following diagram shows the location of the jumpers and the terminating resistor pack for Tandon drives. (Some Percom drives are Tandons; compare your drive to the diagram.) For each drive, set HM and one drive select. [Some Tandon drives do not have head load solenoids. Only a drive select needs to be set for these drives.]

DIAGRAM 15: 5 1/4" Tandons and Some Percoms

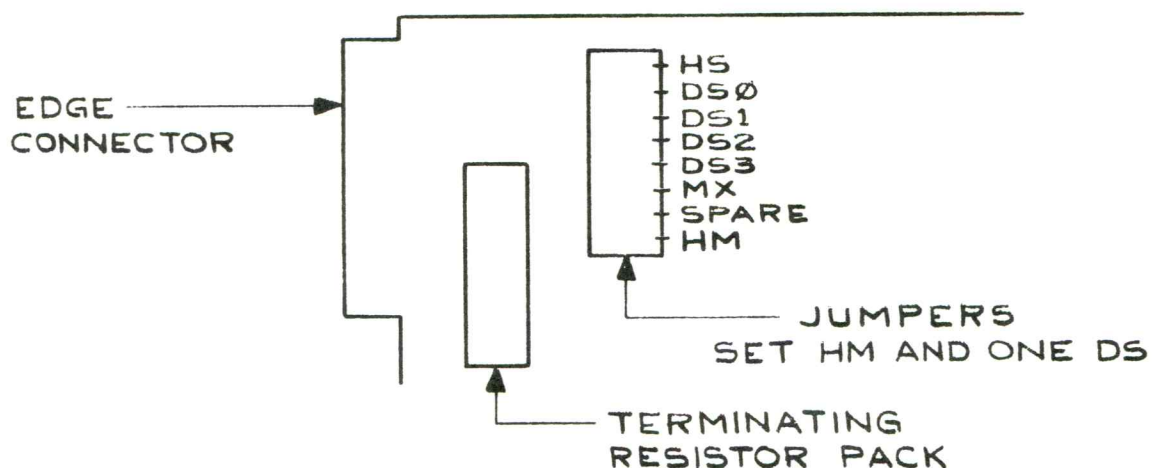

II.4.A2. Configuring MPI, Aerocomp and Some Percom Drives

Diagram 16 shows the jumpers and terminating resistor pack for these drives. On each drive set HM and one drive select. [Some MPI drives do not have head load solenoids. For these drives, only a drive select needs to be set.]

DIAGRAM 16: AEROCOMP, MPI and Some Percom Drives

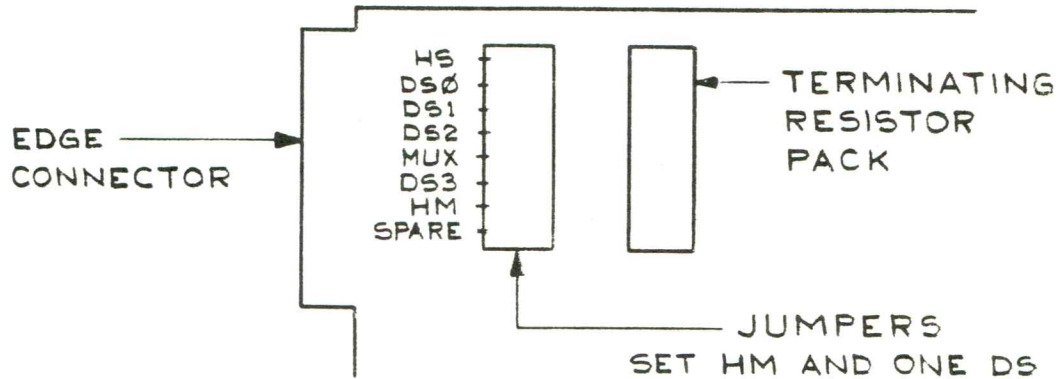

II.4.A3. Configuring Shugart 400 Drives

The following diagram shows the jumpers and the terminating resistor pack for Shugart 400 drives. For each drive, set MH and one drive select.

DIAGRAM 17: Shugart 400s

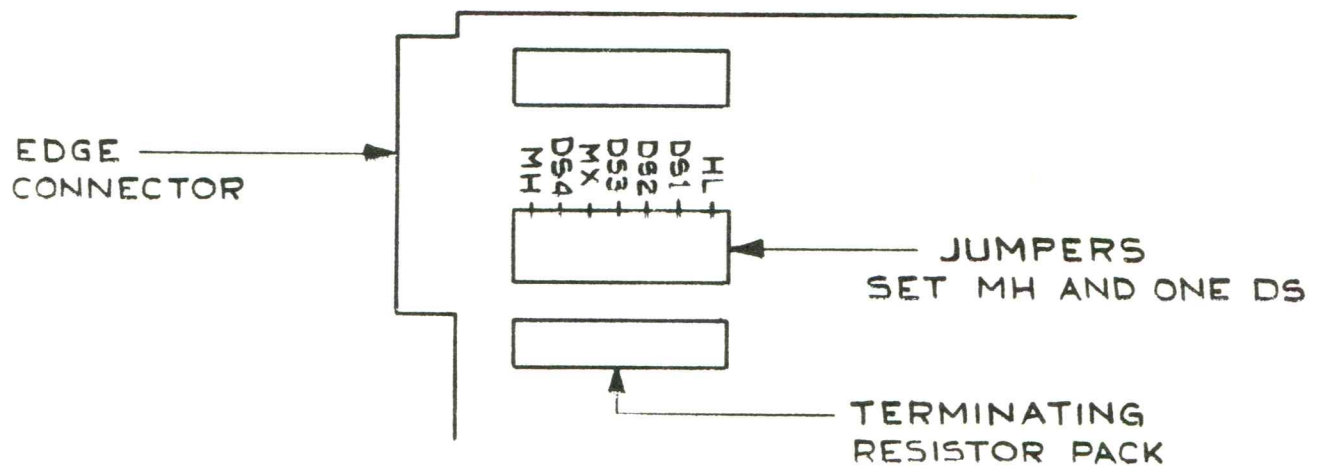

II.4.A4. Configuring Shugart 460 Drives

Shugart 460 drives are 80 track single-sided drives. Instead of having a jumper block, these drives have jumpers in two rows. An option is set by connecting the option's pins with a shunt (a removable connector). For these drives, plug MX and one drive select.

DIAGRAM 18: Shugart 460s

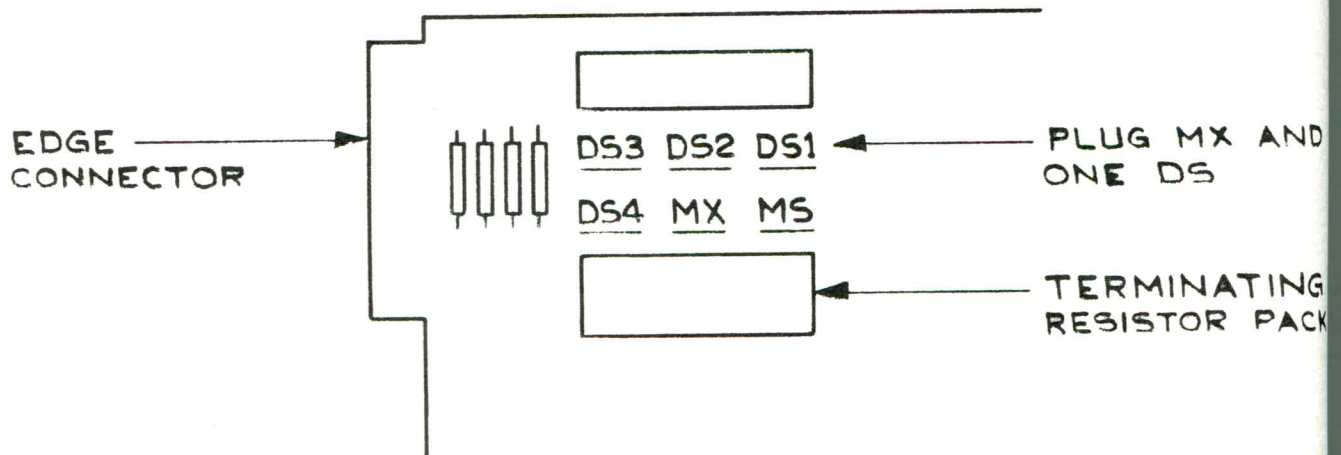

II.4.A5. ATARI 810 Drives:

When using ATARI 810 drives with the ATR8000, connect them to the ATARI Daisy Chain Cable. Decide what drive numbers the drives will be configure the 810 by following the instructions on the back of the drive.

810 drives are set by positioning two switches one white, one black. The possible settings are:

DIAGRAM 19: Configuring an ATARI 810 Drive

DRIVE CODE NO.

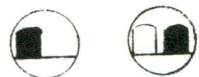

NO. 1 NO. 2



NO. 3 NO. 4

II.4.A6. Radio Shack Drives:

Some Radio Shack drives for the TRS 80 Model I are nonstandard. The following tells how to alter one of these drives to work with the ATR8000. You can permanently change the drive to a standard configuration, or you can install a switch that will enable you to use the drive with either the TRS 80 Model I or the ATR8000.

If you are using a Radio Shack drive cable, drives are configured differently than normal drives. These cables are constructed so that drive select is determined by the connectors on the cable. The first connector makes the drive plugged into it Drive 1, the second Drive 2, and so on. Because the drive number is determined by position on the cable, all four drive selects are plugged active on all the drives. This way, any drive can be reconnected to another connector without changing jumper options.

When using TRS-80 Model I drives on a non-Radio Shack cable, use standard configurations. External Model III drives are standard drives.

II.4.A6A. Redoing a Model I Drive to Run on Either the TRS 80 or the ATR8000

By installing a double pole, double throw (DPDT) switch, TRS 80 Model I drives can be altered so that they will work both on the TRS 80 and on the ATR8000. The following two diagrams show the drive's circuit board. Notice the four marked reference points (A, B, C and D). These points will be used to change the drive.

DIAGRAM 20: Front View of the Model I Drive's Board

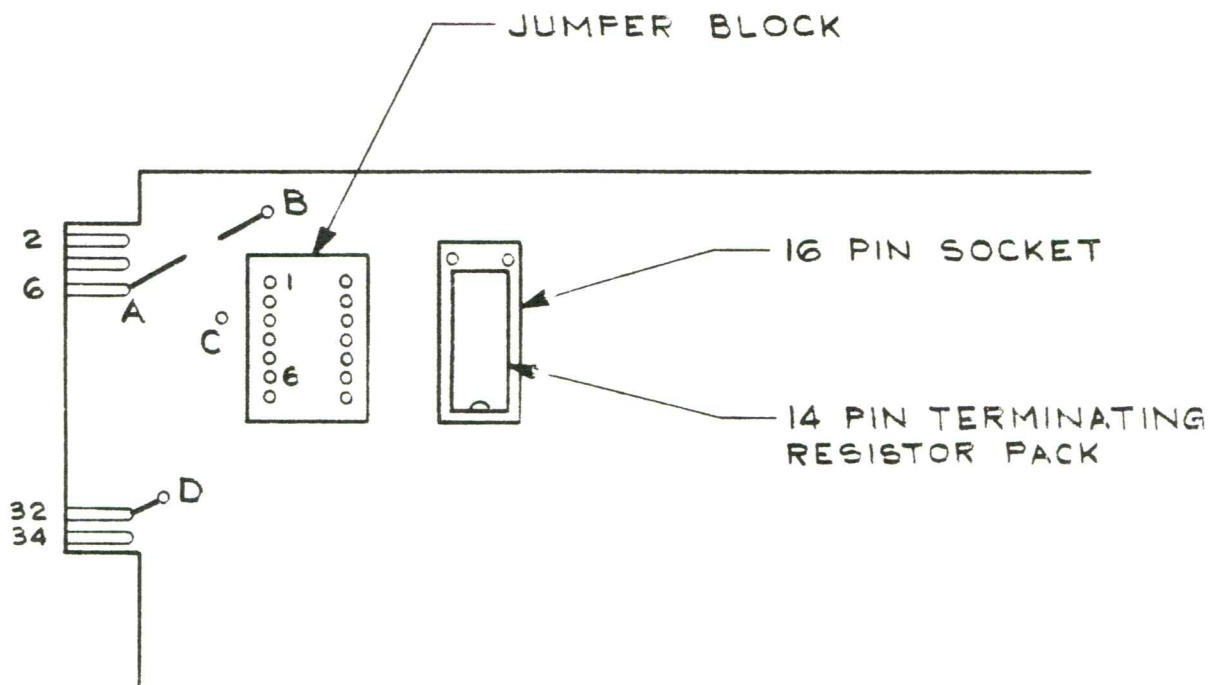
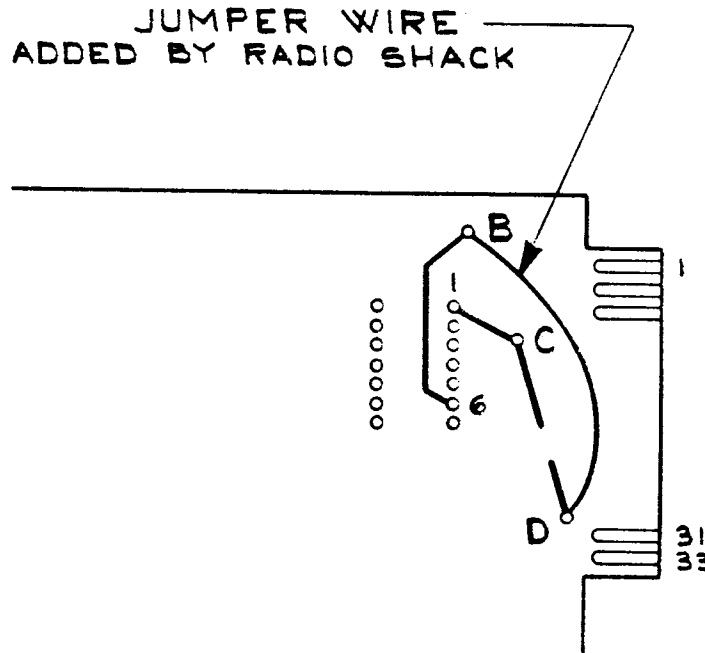

DIAGRAM 20A: Back View of the Model I's Board



The reference points: A is on Pin 6 of the edge connector.

B is above the jumper block. On the front side of the circuit board, the trace that connected B to A has been cut by Radio Shack. On the back side of the circuit board, a trace connects B to Pin 6 of the jumper block.

C is to the side of the jumper block. On the back side of the circuit board, there is a trace that connects C to Pin 1 of the jumper block. Also on this side, the trace that connected C to D has been cut by Radio Shack.

D connects to Pin 32 of the edge connector. On the back side of the circuit board, Radio Shack added a jumper wire between D and B.

Materials: You will need: A soldering iron and solder.

A double pole, double throw switch (DPDT).

Wire for the connections.

Assign the following values to the DPDT switch's connectors:

DIAGRAM 20B: The DPDT Before Connection

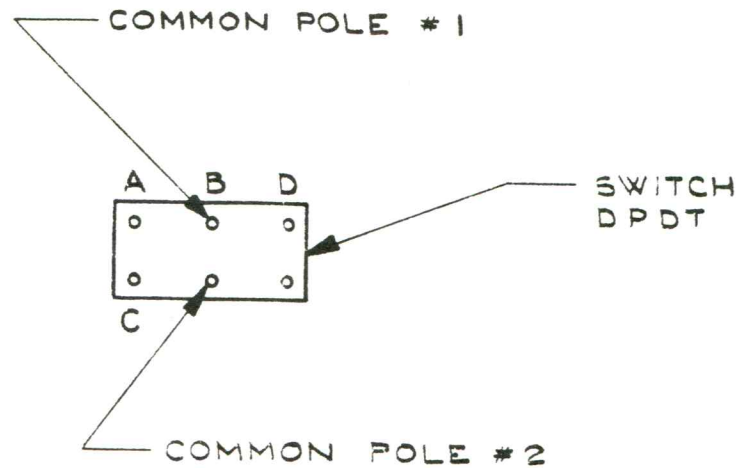

- Step #1 On the back side of the circuit board, remove the jumper wire between D and B.
- Step #2 Connect a wire from A to the A connection on the DPDT switch.
- Step #3 Connect a wire from B to the B connection on the DPDT switch (Common Pole #1).
- Step #4 Connect a wire from C to the C connection on the DPDT switch.
- Step #5 Connect a wire from D to the D connection on the DPDT switch.
- Step #6 On the DPDT switch, connect a jumper between the D connection and Common Pole #2.
- Step #7 If the drive being altered will be Drive number 1, 2 or 3, remove the jumper block from its socket, bend Pin 6 up and reinsert the jumper block in its socket. If the drive being altered will be Drive 4, do not do this.

Using the DPDT Switch

After following the above procedure, the connection to the DPDT switch should look like those shown in Diagram 20C. When the switches are thrown to the A-C side of the switch, the drive is configured as a standard drive and can be used on the ATR8000. When the switches are thrown to the D side of the switch, the drive is configured for the TRS 80.

DIAGRAM 20C: The DPDT Switch After Connections

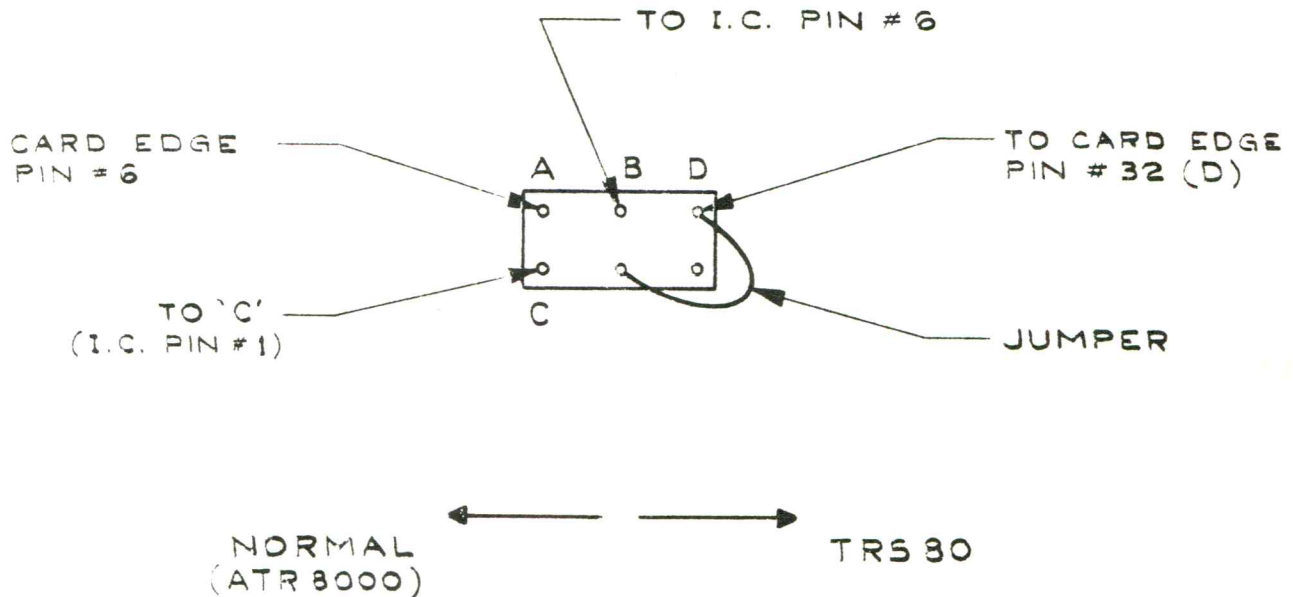

II.4.A6B. Redoing a TRS 80 Drive to be a Standard Disk Drive

To change a TRS-80 drive to be a standard drive, do the following. Use DIAGRAM 20 and 20A for reference. The reference points are described in greater detail in the above subsection.

- Step #1 On the front side of the circuit board, reconnect A and B. (You could solder a wire across the cut in the trace.)
- Step #2 On the back side of the circuit board, break the connection between B and D and connect C and D. (You could remove the Radio Shack jumper wire from B and solder it to C.)

II.4.B. 8" Drives:

8" drives are configured similarly to 5 1/4" drives. The terminal resistor information is the same as for 5 1/4" drives. The drive on the last connector on the Standard Drive Cable must have the terminating resistors set. Some 8" drives have these in a resistor pack, others have spread the resistors out.

Rather than having the jumper options in one place (like 5 1/4" drives), 8" drives have these options in segments in different locations on the circuit board. For their locations, consult a drive manual. As with the 5 1/4" drives, one drive select needs to be active for each drive.

II.4.B1. 8" Drive Configurations for Shugart 800s and 801s:

For this description, jumper means connected (active), open means disconnected.

Jumper T1, T2, T3, T4, T5, and T6 on the drive connected to the last connector on the cable. These are the terminating resistors. (T2 is the drive select pullup resistor.)

On all other drives, jumper T2 and leave T1, T3, T4, T5 and T6 open.

Jumper one drive select (DS 1, DS 2, DS 3, or DS 4), have the others open.

Open B.

Jumper HL, Z, A, C, X*.

* Jumpering X with B open allows the heads to stay loaded when the system switches between drives. This saves head wear-and-tear and quiets drive noise caused by head-banging. It is possible to Jumper B and Open X.

If your drives' power supply can only handle one drive at a time, do not have X jumpered and B open or you'll blow the power supply. **If your power supply can only handle one drive at a time, Jumper B and Open X.**

II.4.B2. Configuring Tandon Thinline Drives (848-1)

For this drive, set one drive select (DS1, DS2, DS3, or DS4). Check to make sure that M1 is set and that M2 is open. If the drive is connected to the last connector on the Standard Drive Cable, leave the terminating resistor pack in, otherwise remove it.

Leave the other jumpers on these drives set the way they come from the factory.

Steve.

check pins

Sequence

*check
Pins*

*DISK
ATR 800
ATARI*

*read on left
point to back*

*check light should be
055*

I.5 Protection from Radio Frequency Interference

I.5.A. Radio Frequency Interference on Nonconnected Radio-TV

The ATR8000 uses and generates radio frequency energy. For this reason it has built-in RFI (Radio Frequency Interference) suppression to filter radio frequency noise. It is possible that the unit could cause interference to radio or television reception while it is operating. If you think the operating ATR8000 is causing interference, turn the unit off and check to see if the supposed interference still exists.

If interference is being caused by the unit, try one or more of the following:

- reorient the receiving antenna on the radio or television having reception difficulties.
- relocate the computer or radio-television.
- if the computer and the radio-television are plugged into the same power circuit, plug the computer into a different power outlet than the radio-television.

If you still have difficulties, you can write to the Federal Communications Commission for their pamphlet, "How to Identify and Resolve Radio-TV Interference Problems." This is available from the United States Government Printing Office, Washington, DC 20402, Stock No. 004-000-0035-4.

I.5.B. Radio Frequency Interference Within the ATR8000 System

Proper lacing of the connection cables will eliminate radio frequency problems within the ATR8000 system. If, during system operation, interference occurs on the television used for a monitor, reposition the system's components (i.e., ATARI, ATR8000, drives, etc.).

To properly lace cables:

- 1) Keep all I/O cables away from the ATR8000 power cable.
- 2) Excess wire between the ATARI and the television adapter must be looped properly. Do not circularly coil the cable as this will cause it to act as an antenna!

Included with the ATR8000 is a ferrite core. This is a round part with a center diameter of one inch. The cable used to connect the ATARI to the television should be looped through this core as shown below.

Notice that the cable loops around the core five times. For the best result, the core should be as close as possible to the television connection.

DIAGRAM 21: Cable Binding for the Television

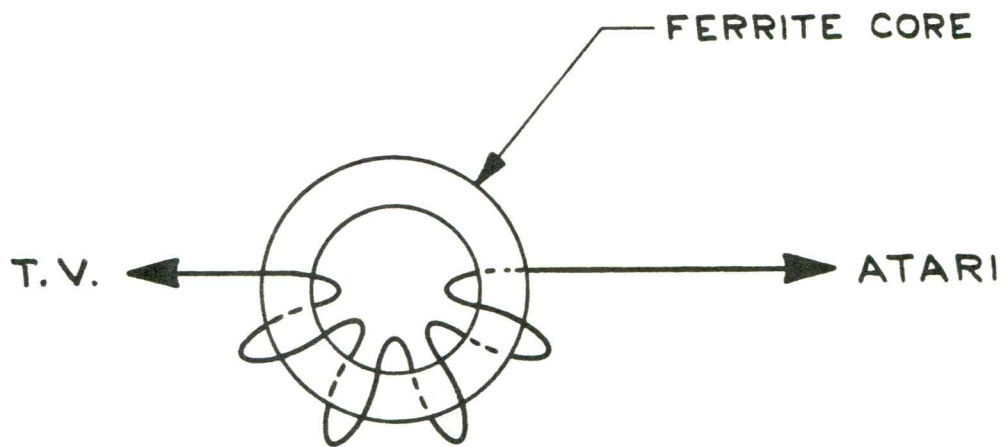
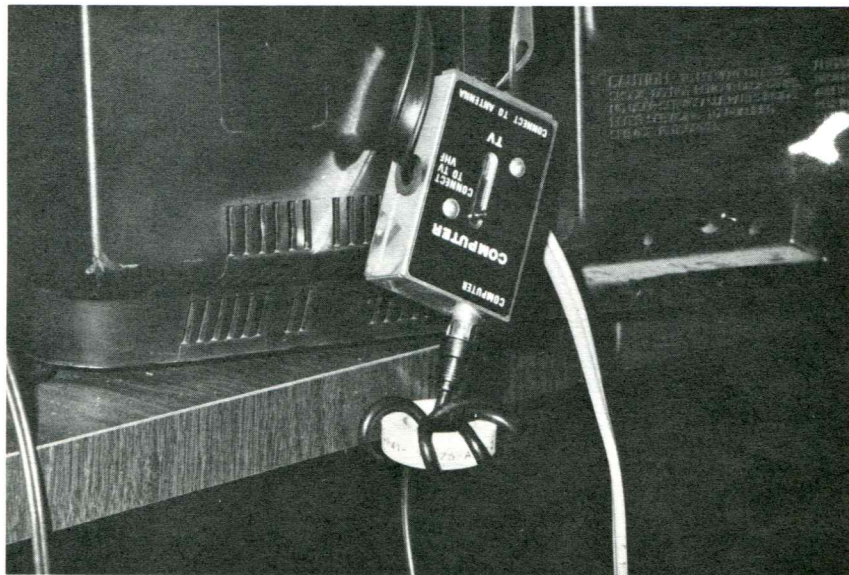

PHOTO #1: Using the Ferrite Core



II.6. The Connection

This section contains detailed connection information. The basic connection is described in Section I.3. Before making the connections, familiarize yourself with the stipulations for connecting your equipment. Use the Table of Contents to find pertinent data.

Refer to the section below that best matches your system's components.

MAKE SURE THAT THE POWER IS TURNED OFF AND THE ATR8000 IS UNPLUGGED BEFORE MAKING ANY CONNECTIONS.

II.6.A. ATARI, ATR8000, 1+ Standard Drives, ATR8000 Cable, Standard Drive Cable, One 8" Adapter for Each 8" Drive

Connecting the above equipment is straightforward. If you are using both 5 1/4" and 8" drives, decide which drive will be Drive 1 (the drive from which the system is booted). For help refer to Section II.3.A.

All 8" drives must have an adapter that connects them to the Standard Drive Cable. Plug the adapter's 50-pin connector onto the drive (with the connector on the upper side of the adapter board) and plug the Standard Drive Cable's connector into the adapter's 34-pin edge connector.

When connecting cables, make sure that Pin 1 on the cable is connected to Pin 1 on the Port. Refer to Section II.1 to learn which pin on each cable is Pin 1. Refer to Diagram 22A to learn where Pin 1 is for each port.

DIAGRAM 22A: The Ports of the ATR8000 (Back View)

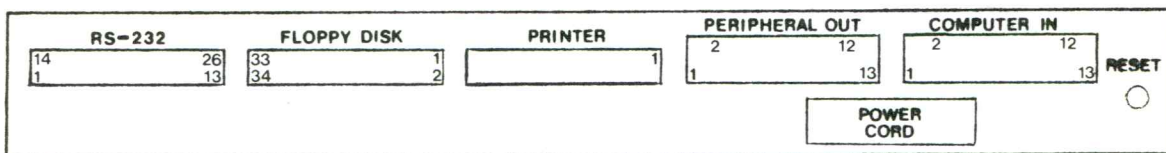
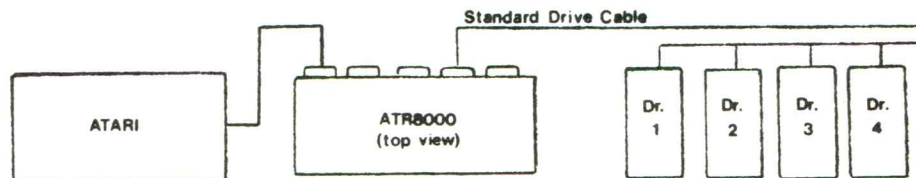

DIAGRAM 22B: Making the Connections (for II.6.A)



Note: These connections are shown in photographs at the end of this subsection.

CONNECTIONS: The ATARI is connected from the peripheral port on the side of the ATARI 800/400 to COMPUTER IN on the ATR8000, using the ATR8000 cable. The Standard Drive Cable connects from the FLOPPY DISK Port of the ATR8000 to the drives. A 4-connector Standard Drive Cable is pictured. Connection using the 2-connector cable is similar.

There must be a drive connected on the Standard Drive Cable's connector that is furthest from the ATR8000 connector (where Drive 1 is pictured above). The above diagram shows one method of drive numbering; drive numbers can be set in any order -- they do not have to be 1,2,3,4; they could be 4,3,2,1 or any other combination. Section II.4 explains this in greater detail and tells how to internally configure drives for drive number.

Photos of the Connection:

PHOTO #2: Connecting the ATR8000 to the ATARI 800/400



When making this and other cable connections, keep all the cables as far away as possible from the ATR8000 power cable.

PHOTO #3: Connecting the Standard Drive Cable to a 5 1/4" Tandon Drive

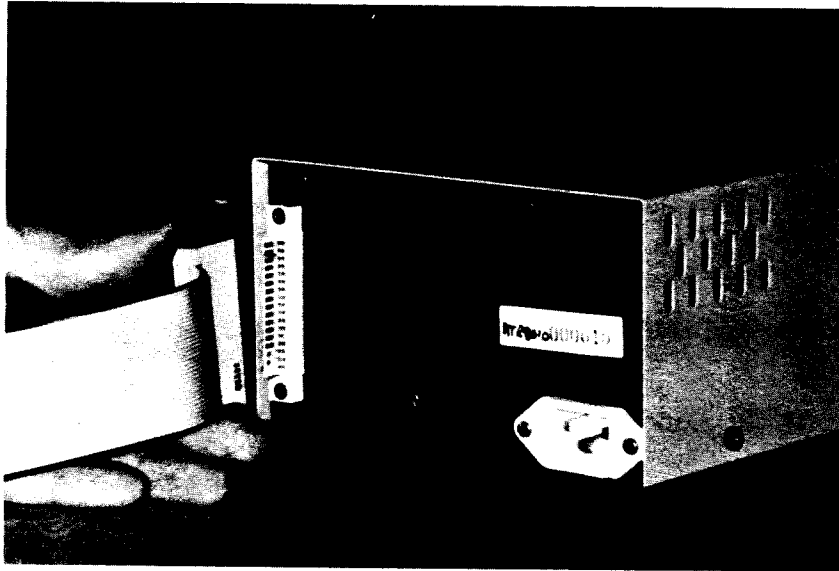

Notice that the last connector on the Standard Drive Cable is used. It must always have a drive connected to it.

PHOTO #4: Connecting an 8" Drive Adapter Board to an 8" Tandon Thinline Drive

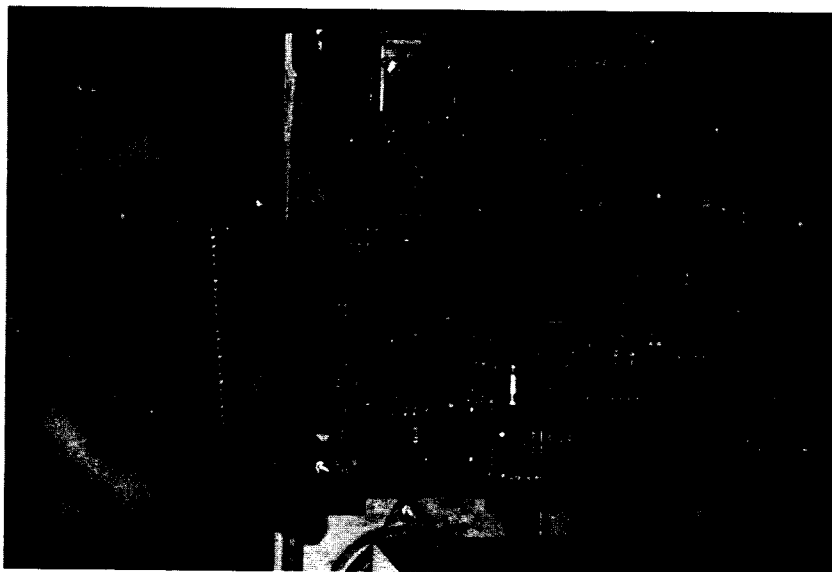

Note the orientation of the adapter board as it plugs onto the drive's connector.

PHOTO #5: Plugging the 8" Adapter Board onto the Standard Drive Cable

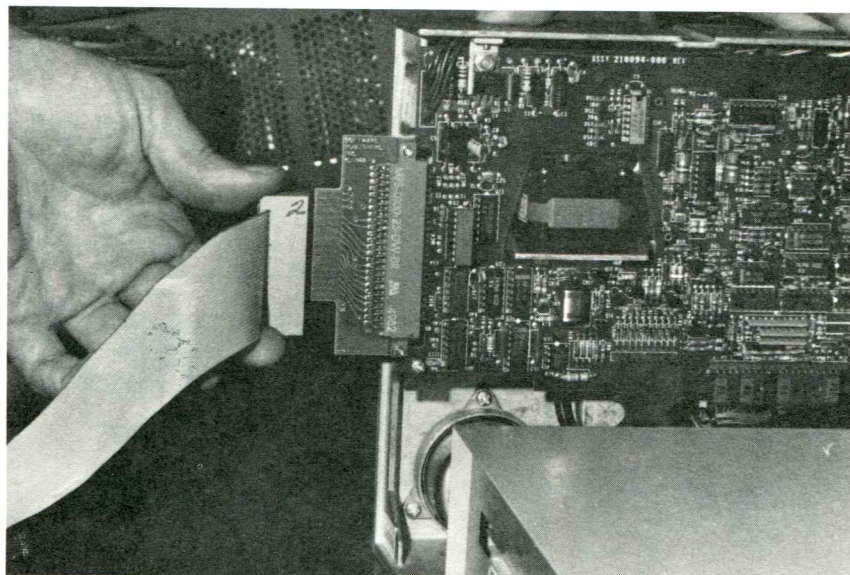

Note the orientation of the drive cable. Pin 1 on the cable and on the adapter board must be aligned.

PHOTO #6: Connecting the Standard Drive Cable to the ATR8000

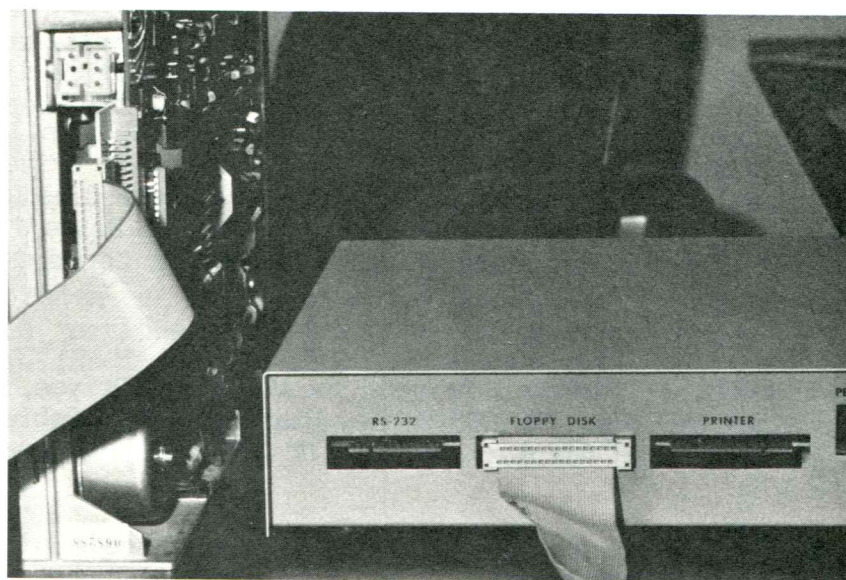

Notice that Pin 1 on the Standard Drive Cable and Pin 1 on the FLOPPY DISK Port are aligned.

II.6.B. ATARI, ATR8000, 1+ Standard Drives, 1+ ATARI 810 Drives, ATR8000 Cable, ATARI Daisy Chain Cable, Standard Drive Cable, One Adapter for Each 8" Drive.

Information on mixing types of drives is in Section II.3. Cable information is in Section II.1. ATR8000 Port information is in Section II.2 and Diagram 22A. Become familiar with all the above information before making any connections.

DIAGRAM 22C: Making the Connections (for II.6.B)

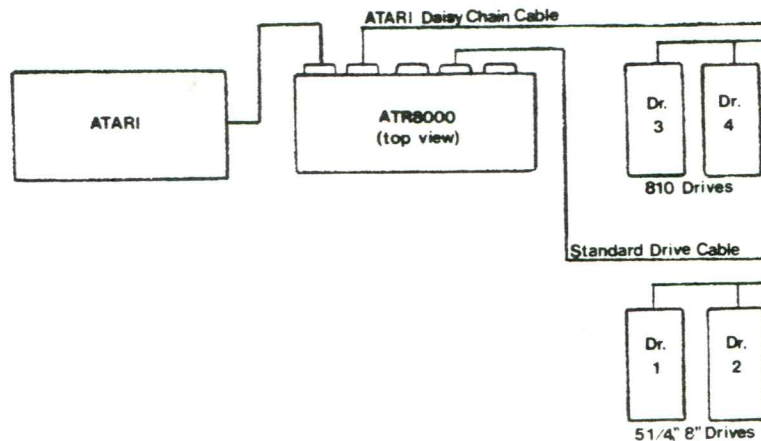

The diagram shows the maximum number of drives (4) with two drives on each drive cable. There could be three standard drives and one 810, or vice versa.

CONNECTIONS:

The ATARI is connected from its peripheral port (on the right side of the ATARI computer console) to the COMPUTER IN Port of the ATR8000, using the ATR8000 cable. The ATARI Daisy Chain Cable connects to the PERIPHERAL OUT Port on the ATR8000. The Standard Drive Cable connects to the FLOPPY DISK Port of the ATR8000.

IMPORTANT:

There must be a drive connected on the Standard Drive Cable's last connector (connector furthest from the ATR8000, Drive 1 above). Each drive must have a unique drive number. For example, if a drive is configured as Drive 1 on the Standard Drive Cable, a drive cannot be configured to be Drive 1 on the ATARI Daisy Chain Cable. Drives are configured internally for drive number in Section II.4.

II.6.C. ATARI, ATR8000, 1+ Standard Drives, 1+ ATARI 810 Drives, Printer, Modem, ATARI 850 Box, ATR8000 Cable, Standard Drive Cable, ATARI Daisy Chain Cable, One 8" Adapter for Each 8" Drive.

There are many ways to connect all or most of the above equipment. Before reading this section, read Section II.3 to learn about the peripherals and the best way to connect them. Also read Sections II.1 and II.2 to learn where Pin 1 is located on both the cables and the ports. Pin 1s must match for proper connections. Follow the subsection below that best matches your equipment.

II.6.C1. Connection Without the 850

DIAGRAM 22D: Making the Connections (for II.6.C1.)

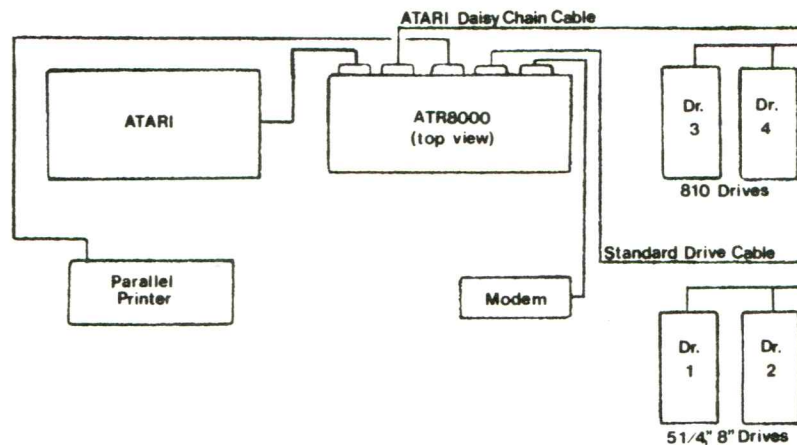

NOTES: If you connect a serial printer, the modem will have to be disconnected to use the printer. To use both peripherals at the same time, connect a parallel printer.

CONNECTIONS:

The ATARI is connected to the COMPUTER IN Port of the ATR8000, using the ATR8000 cable. The ATARI Daisy Chain Cable is connected to the PERIPHERAL OUT Port of the ATR8000. The Parallel Printer Cable is connected to the PRINTER Port (a parallel port). The Standard Drive Cable is connected to the FLOPPY DISK Port. The modem is connected to the RS-232 Port.

There can be a total of four disk drives connected to the ATR8000. There must be a drive connected on the last connector of the Standard Drive Cable (the connector furthest from the ATR8000, Drive 1 above). Internal configuration of drives is discussed in Section II.4.

II.6.C2. Connection With the 850

The 830 ATARI Modem can be connected to the ATARI 850 Interface Module. To be used with CP/M, peripherals must be directly connected to the ATR8000, not through an 850. (Read Section II.3 for further details.)

To use the 850, the ATARI is connected to the 850 which is connected to the ATR8000 COMPUTER IN Port. Then, the modem and/or printer is connected to the 850.

DIAGRAM 22E: Making the Connections (for II.6.C2.)

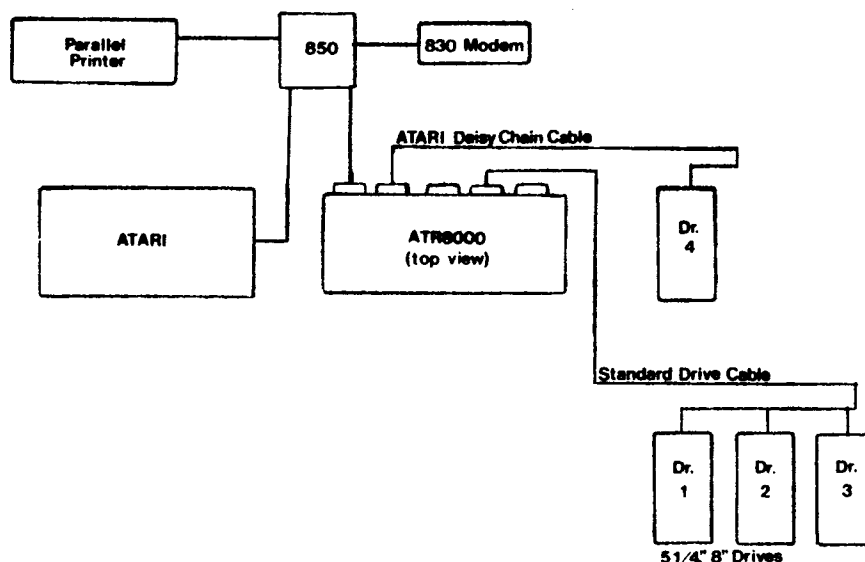

CONNECTIONS:

The ATARI is connected to the 850 which is connected to the COMPUTER IN Port of the ATR8000. The 830 Modem is connected to the 850. The ATARI Daisy Chain Cable is connected to the PERIPHERAL OUT Port. The parallel printer is connected to the 850. The Standard Drive Cable is connected to the FLOPPY DISK Port.

NOTE: Only ATARI DOS and OS/A+ printing can be done while the printer is connected to the 850. The 850 must be disconnected and the printer must be connected to the ATR8000 for CP/M printing.

NOTE: For CP/M operation, a modem must be directly connected the ATR8000.

NOTE: There must be a drive connected on the last connector on the Standard Drive Cable (Drive 1 above). Drive numbers must be unique. Drives are internally configured for numbers in Section II.4.

II.6.C3. Connecting a 40 Column Printer

A 40 column printer is connected on the ATARI Daisy Chain Cable. 810 drives are also connected on this cable. Remember that a 40 column printer cannot be used with CP/M.

Make sure that Pin 1 on each cable is connected to Pin 1 on the corresponding port. See Sections II.1 and II.2 for details.

DIAGRAM 22F: Making the Connections (for II.6.C3.)

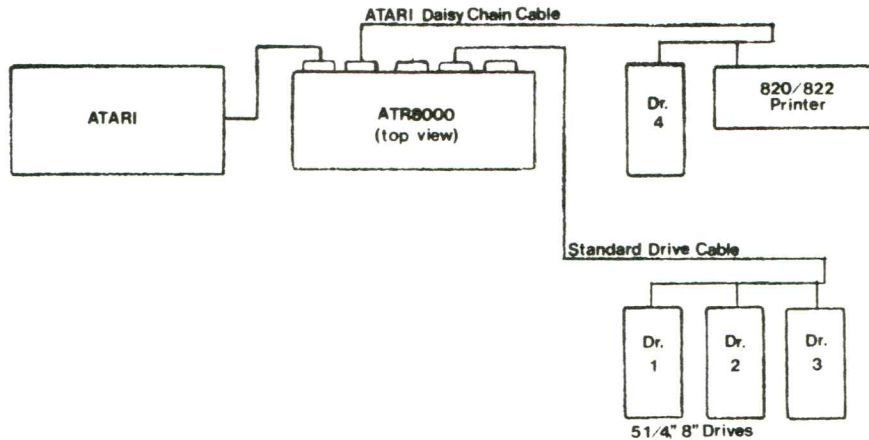

CONNECTIONS:

The ATARI is connected to the COMPUTER IN Port of the ATR8000, using the ATR8000 cable. The ATARI Daisy Chain Cable is connected to the PERIPHERAL OUT Port. The Standard Drive Cable is connected to the FLOPPY DISK Port.

NOTE: The 820/822 printer can only be used to print under ATARI DOS or OS/A+.

NOTE: There must be a drive connected on the last connector of the Standard Drive Cable (Drive 1 above). Internal configuring of drives is discussed in Section II.4.

II.6.D. Other Connections

If your equipment does not directly match one of the above connection sections, merge the portions of the sections that describe your equipment. Follow the guidelines for limitations that some connections will incur. As a rule, whenever possible, connect directly to the ports of the ATR8000.

Diagram 23: Jumper Option Locations

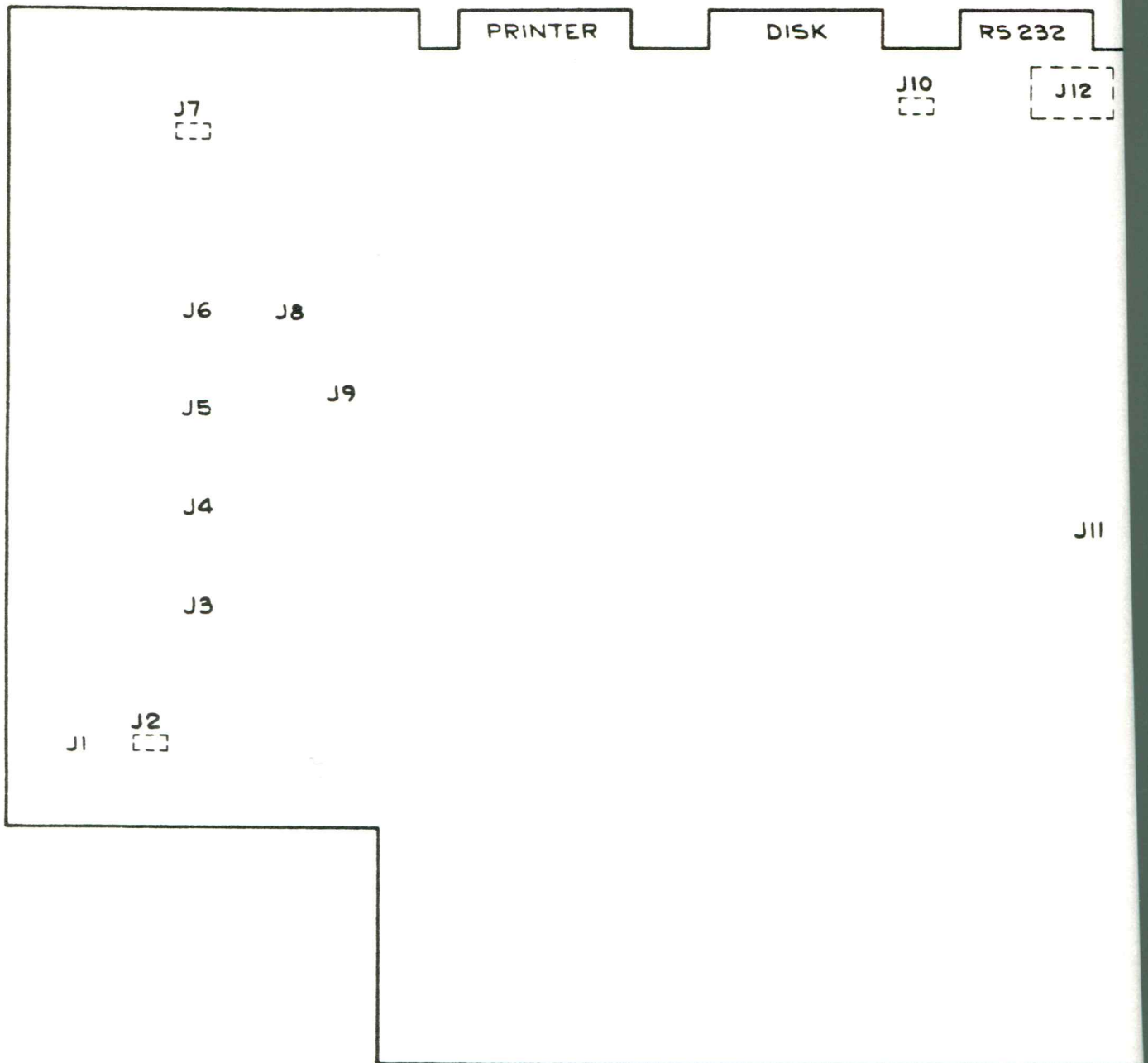

II.7. ATR8000 Jumper Options

The circuit board of the ATR8000 has 12 jumper options. For the positions of these jumper options, refer to the diagram of the circuit board on the preceding page. The jumper options and the meaning of the configurations are explained below.

TURN THE POWER OFF THE ATR8000 AND UNPLUG IT BEFORE MAKING ANY CHANGES. DO NOT TURN THE POWER BACK ON THE SYSTEM UNTIL ALL JUMPERS CHANGES ARE COMPLETED AND DOUBLE-CHECKED FOR ACCURACY. IF YOU DO NOT MAKE THESE CHANGES PROPERLY, THE ATR8000 MAY BE DAMAGED.

II.7.A. 16k or 64k — J1, J2, J3, J4, J5, J6, J8

The way these jumper options are configured depends on whether the ATR8000 has 16k or 64k of RAM. Diagram 24 shows the proper configuration for each. A bar between two points indicates a connection; no bar means the space is open.

The default for these jumpers is for 64k of RAM. These jumper connections for the 64k ATR8000 are traces on the circuit board. If you purchased a 16k ATR8000, we cut these default connections and properly jumpered the board for 16k of RAM. [Older ATR8000 circuit boards were default configured for 16k RAM. By comparing Diagram 24 to your board, you can determine how your board is configured.]

DIAGRAM 24: 16k or 64k — J1, J2, J3, J4, J5, J6, J8

For 16k ATR8000:

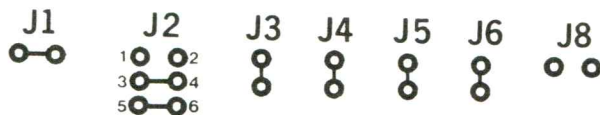

For 64k ATR8000:

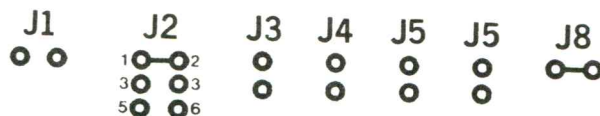

Notice that the 64k jumpers are the exact opposite of the 16k jumpers. If you have a 16k ATR8000 and are converting it from 16k to 64k, break the 16k connections, then make the proper 64k jumper connections. Further instructions for converting the ATR8000 to 64k are in Section IV.1.

II.7.B. ATARI or RS-232 Terminal — J7, J10

The configuration of these jumpers depends on whether an ATARI or an RS-232

terminal is connected to the ATR8000 at the COMPUTER IN Port. An RS-232 terminal may be connected (in place of the ATARI) to the 64k ATR8000. (There are no handshake lines for the RS-232 terminal.) For other information about connecting an RS-232 terminal, refer to Section II.8.

These jumper options have pin strips in them. Connections are made by plugging a shunt between pins. [A shunt is a movable connector that connects two pins together.]

The default for these jumper options is for the ATARI. If you are using an RS-232 terminal, change the connections following Diagram 216.

DIAGRAM 25: ATARI or RS-232 Terminal — J7, J10



If you plan to switch between using an ATARI and an RS-232 terminal with the ATR8000, make sure that J7 and J10 are properly configured for the component you are using.

II.7.C. 2k or 4k Operating ROM — J9

This jumper option relates to the operating ROM. The ATR8000 comes with a 4k operating ROM, so the default configuration is set for the 4k ROM.

DIAGRAM 26: 2k or 4k Operating ROM — J9



II.7.D. Disabling the ATR8000 Printer Ports — J11

When active (plugged), this jumper option disables the printer ports of the ATR8000. The ports can also be disabled by running PRINTOFF.BAS before

printing. There are two instances in which J11 is used:

- 1 - For ATARI DOS and OS/A+ printing if an 850 is connected to the system. (An 850 cannot be connected during CP/M operation.)
- 2 - If a 40 column printer is connected to the ATARI Daisy Chain Cable. This printer can only be used for ATARI DOS and OS/A+.

DIAGRAM 27: Printer Port Disabling — J11



II.7.E. RS-232 Configuring — J12

This is the most complex of the jumper options. The configuration of this jumper option depends on what peripheral is run from the RS-232 Port of the ATR8000. Look at the Diagram 28.

DIAGRAM 28: RS-232 Configuring — J12

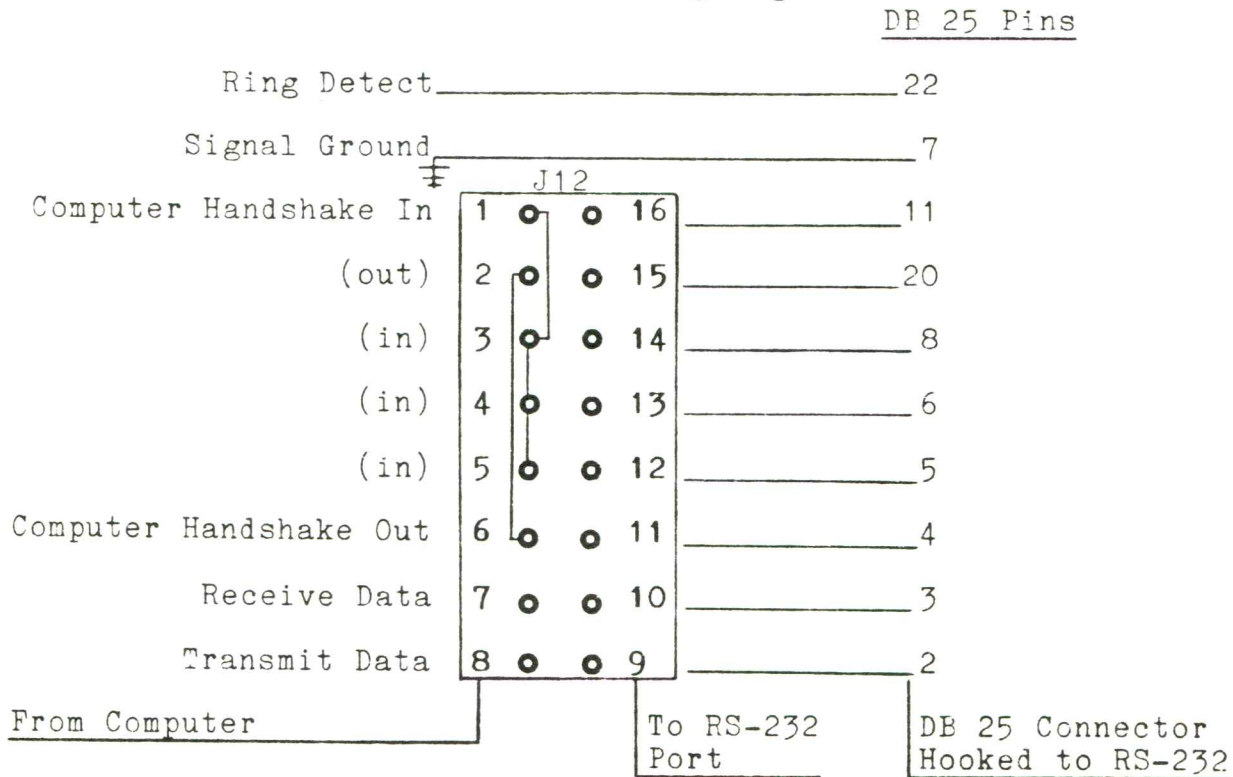

Notice that the left side of J12 (Pins 1-8) has ATR8000 signals coming into it. When pins from the left side are connected to pins on the right side of J12 (Pins 9-16), the signals are sent across the jumper option to go to the DB 25 connector that interfaces the peripheral to the RS-232 Port.

The configuration of J12 depends upon what the connected RS-232 peripheral needs. Some sample configurations are shown below. To connect a peripheral not listed below, consult the connection section of that peripheral's manual to see what signals need to be interfaced. Rely on Diagram 28 to see what pins of the DB 25 connector are connected to Pins 9-16 of J12.

J12 is default configured to run an Epson serial printer.

DIAGRAM 28A: Configuration of J12 to Connect an Epson Serial Printer (the Default)

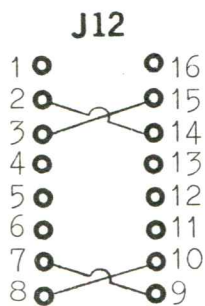

DIAGRAM 28B: Configuration of J12 to Connect an RS-232 Terminal to the RS-232 Port to Communicate with the ATARI

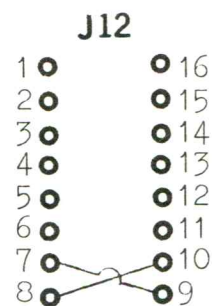
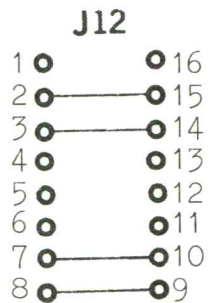

DIAGRAM 28C: Configuration of J12 to Connect the D.C. Hayes Smart Modem or the ATARI 830 Modem to the RS-232 Port



II.8. Connecting an RS-232 Terminal to the ATR8000

An RS-232 terminal may be connected to the 64k ATR8000 in place of the ATARI. The terminal's parameters must be 9600 baud, odd parity and 7 bits. There are no handshake lines for the terminal.

The terminal should be able to emulate the ADM 3A protocol. A terminal will run CP/M software. (Since it is not an ATARI, it will not run ATARI DOS or OS/A+.)

To connect a terminal, follow the steps below.

- STEP 1 Turn off the power on the ATR8000 and unplug it from the electrical socket before continuing.
- STEP 2 Properly configure J7 and J10 as shown in Section II.7.B. Diagram 25 shows the proper shunt connections for an RS-232 terminal.
- STEP 3 Get a special terminal cable from SWP. This cable has an "ATARI" connector on one end that plugs into the COMPUTER IN Port of the ATR8000. The other end of the cable connects to the terminal. Connect the cable.
- STEP 4 Double check to insure that the jumpers are correct and that the cable is properly connected before repowering and plugging in the ATR8000.

Booting CP/M from a terminal is slightly different than booting it with an ATARI. To boot CP/M, do the following:

- STEP 1 If the system has been running, press the reset button on the ATR8000. Otherwise, power up the system (ATR8000, terminal, drives, etc.).
- STEP 2 The drives' motors will run for approximately 3 seconds. When they stop, press <RETURN>. ATRMON and its prompt (#) should show on the screen.
- STEP 3 Put the CP/M disk in Drive A and type: B<RETURN>. (B stands for boot.)

CP/M is now booted. For ATR8000 CP/M information, consult the ATR8000 CP/M Supplement.

III. Software

This section is divided into three subsections. The first covers ATARI DOS and the ATR8000. For normal ATARI DOS operations, consult the ATARI DOS manual. The second describes OS/A+ and the ATR8000; this section is a supplement to the OS/A+ manual. The last section contains ATR8000 System ROM information. For information about SWP ATR8000 CP/M, refer to the ATR8000 CP/M Supplement.

The 2.0 ROM in your ATR8000 is able to read and run copy-protected ATARI software. If for any reason you discover a program that will run on the ATARI but not through the ATR8000, let us know.

This ROM has several special features including an automatic printer buffer and a parallel printer driver. For ATARI DOS and OS/A+ printing, 16k ATR8000s have a 4k buffer, 64k ATR8000s have a 48k buffer. The ROM contains a parallel printer driver for ATARI DOS and OS/A+ printing. Serial printing can be done by running SERDRV.BAS, a serial printer driver that is listed in the ATARI DOS section.

The ATR8000 System ROM section has been included for users that want to know more about the internal workings of the ATR8000 ROM. Programmers should use this section for reference purposes.

Under ATARI DOS and OS/A+, the ATR8000 is a slave processor to the ATARI. It operates as a double density disk interface that runs up to four disk drives, a printer and a modem. To run CP/M, the 64k ATR8000 transmits a terminal program to the ATARI, then takes control of the system, becoming the master processor. An RS-232 terminal can be connected to the 64k ATR8000 in place of the ATARI 800/400 to run CP/M.

III.1. ATARI DOS

ATARI DOS operates as it did on the ATARI before the ATR8000 was connected. ATARI BASIC, ATARI programs, and the functions of ATARI DOS all run normally. This DOS (on a 5 1/4" disk) can be booted from a standard 5 1/4" drive as well as from an ATARI 810.

As is explained later, it is possible to run this DOS from an 8" drive. This will only access 720 of the possible 2002 sectors on the disk. Although all of the available disk space cannot be used, it can be an advantage for 8" drive users that also want to run double density DOSes on the system. For these users, this method saves having to reconfigure the disk drives when changing DOSes.

III.1.A. Booting ATARI DOS

To boot ATARI DOS with the ATR8000, do the following:

- STEP 1 Turn the power on the disk drives, the ATR8000 and the TV/monitor.
- STEP 2 Reset the ATR8000. (The reset button is in the back of the ATR8000, next to the power cord.)
- STEP 3 Put the ATARI DOS disk in Drive 1. Drive 1 can be an ATARI 810 or a standard 5 1/4" drive.
- STEP 4 Turn the ATARI 800/400 on. If the BASIC cartridge is in the ATARI, the READY prompt will show on the screen. To enter ATARI DOS, type: DOS<return>.

If there is not a BASIC cartridge in the ATARI when it is powered up, the DOS's D1: prompt will show on the screen.

III.1.B. Copying ATARI DOS to an 8" Disk

To copy ATARI DOS to an 8" disk, first connect the drives so that a standard 5 1/4" or an 810 drive is Drive 1 and an 8" drive is another drive number. Then follow the ATARI DOS procedure for making a systems disk from your master disk. If you are unsure about how to do this, follow the steps below.

- STEP 1 Connect the disk drives so that an 810 or a standard 5 1/4" drive is Drive 1 and an 8" drive is Drive 2. (For help refer to Section II.)
- STEP 2 Boot ATARI DOS. (For help refer to the above section.) If the ATARI BASIC cartridge is in the ATARI 800/400, the READY prompt will appear. Type DOS and press <RETURN>. (If no BASIC cartridge is in the ATARI 800/400, the DOS's D1: prompt will appear on the screen.)
- STEP 3 To format the 8" disk that ATARI DOS will be written onto, type I for the FORMAT option. When asked which drive to format, type 2 and press

<RETURN>. Insert a blank 8" disk into Drive 2 and close the drive door.

- STEP 4 When prompted to TYPE Y TO FORMAT DISK 2, type Y and press <RETURN>. When the formatting is complete, the message SELECT ITEM OR RETURN FOR MENU will appear on the screen.
- STEP 5 To copy the DOS onto the formatted 8" disk, type H and press <RETURN> to select the WRITE DOS FILES option.
- STEP 6 When asked which disk to write the files to, type 2 and press <RETURN>. When asked for verification, type Y and <RETURN>.
- STEP 7 When the operation is complete, the message SELECT ITEM OR RETURN FOR MENU will reappear on the screen. At this point you can write the MEM.SAV file on the disk as the ATARI DOS manual recommends. To do this, type N and press <RETURN> (for CREATE MEM.SAV). Then type Y and press <RETURN>. When the procedure is done, the message SELECT ITEM OR RETURN FOR MENU will reappear on the screen.

III.1.B1. Booting ATARI DOS from an 8" Disk

To boot ATARI DOS from an 8" disk, have the drives numbered so that Drive 1 is an 8" drive. Then follow the normal ATARI DOS booting procedure (described in Section III.1.A).

III.1.C. Disks

The ATR8000 reads formatted soft sector disks. By following a simple procedure it is also possible to be able to read hard sector media that has been formatted soft sector (like some ATARI games are) and to read and write on the flipped side of a disk.

III.1.C1. Hard Sector Disks

Some ATARI programs come on hard sector disks that have been soft sector formatted. Hard sector disks have multiple index holes, whereas soft sector disks only have one index hole. To run hard sector disks that have been soft sector formatted, you need a basic understanding of how the ATR8000 looks at disks.

When the ATR8000 is turned on, the ATR8000 doesn't know if the system's drives are 5 1/4" or 8" or a mixture. The ATR8000 analyzes the index hole of the disk in the drive to determine the disk size. It counts the time it takes for the disk to make one revolution, using the index hole as the start and stop points. A 5 1/4" disk rotates at 300 RPM or less. An 8" disk rotates at 360 RPM. The single index hole in a soft sector disk makes this analysis possible. The multiple index holes in a hard sector disk disrupt the analysis.

The first drive is analyzed for size when the system is booted. Other drives are analyzed for size the first time they are selected after a boot. After a drive has been analyzed for size, it will not be reanalyzed unless the system is rebooted.

You can determine if a disk is hard sectored by doing the following:

Gently spin the disk in the disk jacket. Watch for index holes. A hard sectored disk will have several holes, a soft sectored disk has only one.

To run a soft sectored formatted hard sectored disk when the system has just been booted, do the following:

- #1 Boot using a soft sectored disk in the first drive. Remove this disk.
- #2 Put the soft sectored formatted hard sectored disk in the first drive. It will now run properly.

To boot a soft sectored formatted hard sectored disk, do the following:

- #1 Boot using a soft sectored disk in the first drive. Remove this disk.
- #2 Turn the ATARI 800/400's power off.
- #3 Put the hard sectored disk in the first drive and turn the ATARI's power on. It will now run properly.

If the drive from which a soft sectored formatted hard sectored disk will be run from has already been selected with a soft sectored disk in it, it is not necessary to do anything special.

III.1.C2. Flipped Disks

You can read and write on the back side, flipped side, of disks for ATARI operation. (We do not recommend this!) The flipped side of a disk cannot be formatted unless:

- 1) The drive is a Pertec or Aerocomp type "flippy," or
- 2) A second index hole is punched (in the proper place) in disks that are used as flippies.

The back side of the disk can be used if the drive containing the flipped disk has already been selected while it held a normal disk. The reason for this is index hole analysis explained in the preceding section.

To use a flipped disk in a drive that has not been selected since the computer was booted, do the following:

- #1 Place a disk in the drive normally. (Do not use the back side of a disk.)
- #2 Select the drive. (For example, for Drive 2 you type: D2.) During this process the computer looks for the index hole of the disk.
- #3 After the drive has been selected, the original disk may be removed and a flipped disk may be inserted.

III.1.D. Modems

An ATARI 830 Modem may be run through an ATARI 850 Interface Module. While the 850 is connected to the ATR8000 system, the printer can only be used if it is also connected to the 850 and the printer ports of the ATR8000 are disabled. The printer ports can be disabled either by using J11 or by running the SWP BASIC program, PRINTOFF.BAS, before printing.

When connected on the same system, signals are sent to the printer from both the 850 and the ATR8000. PRINTOFF.BAS (an ATARI BASIC program) or J11 disable the ATR8000's printer driver so that it won't interfere with the signals between the 850 and the printer.

For more information, refer to Section II.3.

III.1.D1. PRINTOFF.BAS

Using ATARI BASIC, enter this BASIC program as listed below. When run, it disables the ATR8000's printer driver to allow the ATARI 850 Interface Module to run the printer. (As described later, it also is used to run an 820/822 printer from the ATARI Daisy Chain Cable). PRINTOFF.BAS will have to be rerun if the computer is rebooted or after PRINTEON.BAS is run.

Run PRINTOFF.BAS before printing. [From ATARI BASIC, type: RUN"D:PRINTOFF.BAS<RETURN>. The computer will respond: PRINTER OFF.] If you attempt to print from the ATR8000's PRINTER Port while PRINTOFF.BAS is active, ERROR 138 will show on the screen.

PRINTOFF.BAS

```
100 REM <<PRINTOFF.BAS>>
110 DIM BUF$(3)
120 Z=ADR(" ")
130 DATA 104,76,89,228
140 FOR I=0 TO 3
150 READ X
160 POKE Z+I,X
170 NEXT I
180 DCB=768
190 DATA 90,1,83,0,0,0,1,0,3,0,56,255
200 FOR I=0 TO 11
210 READ X
220 POKE DCB+I,X
230 NEXT I
240 X=USR(Z)
250 A=ADR(BUF$)
260 X=INT(A/256)
270 POKE DCB+5,X
280 POKE DCB+4,A-X*256
290 GOSUB 2000
300 POKE DCB+2,ASC("S")
310 POKE DCB+3,0
320 D=PEEK(A)
330 POKE DCB+10,D
340 D=PEEK(A+1)
350 POKE DCB+11,D
360 X=USR(Z)
370 GOSUB 2000
380 POKE A+2,255
390 POKE DCB+2,ASC("W")
400 POKE DCB+3,128
410 X=USR(Z)
420 PRINT "PRINTER OFF"
430 END
2000 POKE DCB+2,ASC("R")
2010 POKE DCB+3,64
2020 POKE DCB+10,3
2030 X=USR(Z)
2040 RETURN
```

III.1.D2. PRINTON.BAS

This program reactivates the printer driver of the ATR8000 after it has been disabled by PRINTOFF.BAS. (If the computer is rebooted, there is no need to run PRINTON.BAS.)

Under ATARI DOS, enter this program as listed below. To run it, type: RUN"D:PRINTON.BAS<RETURN>. The system will respond: PRINTER ON.

PRINTON.BAS

```
100 REM <<PRINTON.BAS>>
110 DIM BUF$(3)
120 Z=ADR("  ")
130 DATA 104,76,89,228
140 FOR I=0 TO 3
150 READ X
160 POKE Z+I,X
170 NEXT I
180 DCB=768
190 DATA 90,1,83,0,0,0,1,0,3,0,56,255
200 FOR I=0 TO 11
210 READ X
220 POKE DCB+I,X
230 NEXT I
240 X=USR(Z)
250 A=ADR(BUF$)
260 X=INT(A/256)
270 POKE DCB+5,X
280 POKE DCB+4,A-X*256
290 GOSUB 2000
300 POKE DCB+2,ASC("S")
310 POKE DCB+3,0
320 D=PEEK(A)
330 POKE DCB+10,D
340 D=PEEK(A+1)
350 POKE DCB+11,D
360 X=USR(Z)
370 GOSUB 2000
380 POKE A+2,64
390 POKE DCB+2,ASC("W")
400 POKE DCB+3,128
410 X=USR(Z)
420 PRINT "PRINTER ON"
430 END
2000 POKE DCB+2,ASC("R")
2010 POKE DCB+3,64
2020 POKE DCB+10,3
2030 X=USR(Z)
2040 RETURN
```

III.1.E. Printers

There are several considerations for connecting a printer to operate with ATARI DOS.

- 1) **820/822 Printers.** Either of these 40 column ATARI printers connects to the ATARI Daisy Chain Cable. Before printing, the PRINTER Port of the ATR8000 must be told not to interfere by using J11 or by running PRINTOFF.BAS.

To turn the ATR8000's PRINTER Port back on after PRINTOFF.BAS has been run, you can either reboot the computer or run PRINTON.BAS.

- 2) **Printing While Using the 830 Modem if the ATARI 850 Interface Module is Connected to the System.** If the 850 has been connected to run the ATARI 830 Modem, to print data received through the modem, the printer must be connected to the 850 box. You must also disable the printer ports of the ATR8000 by using J11 or by running PRINTOFF.BAS.

If the 830 Modem isn't being used at the time of printing, but it is connected to the ATR8000 system, there are two ways to use an 80 column printer for ATARI DOS:

- 1) Disconnect the 850 and connect the printer to the ATR8000's PRINTER Port.
- 2) Connect the printer to the ATARI 850 and use J11 or run PRINTOFF.BAS before printing.

As with ATARI operation, an 820/822 printer will not operate if an 850 is connected to the system.

III.1.E1. Printing Features in the ATR8000 ROM

The ATR8000's ROM has an automatic printer buffer for ATARI DOS and OS/A+ printing. This buffer is 4k for the 16k ATR8000 and is 48k for the 64k ATR8000. To make use of this feature, the printer must be directly connected to either the PRINTER Port or the RS-232 Port of the ATR8000.

The only function that cannot be done while the buffer is active is disk initializing. Disk initializing takes too much memory to be done while printing is also being done.

The ATR8000 ROM contains a parallel printer driver. This driver runs a parallel printer connected to the PRINTER Port of the ATR8000. To print, simply follow the normal print commands of the program or DOS you are using.

III.1.E2. SERDRV.BAS: a Serial Printer Driver for ATARI DOS and OS/A+

A serial printer can be connected to the RS-232 Port of the ATR8000. J12, the jumper option that configures this port, is factory set to support an Epson serial printer. If you use a different type of serial printer, consult the printer's manual and Section II.7 to properly configure J12.

Serial printer drivers for printing under CP/M are explained in the ATR8000 CP/M Supplement. The following serial printer driver is for serial printing under ATARI DOS or OS/A+.

SERDRV.BAS is a dtrline printer driver. To work with this driver, your printer needs to use Pin 20 for hard wire handshaking. The driver is set to have no parity and a word length of 8 bits. You may choose a baud rate of 1200, 2400, 4800 or 9600.

Enter this program in ATARI BASIC, then run it before printing (if the computer is rebooted or reset, the program will have to be run again). When the program has been loaded, the message SERIAL DRIVER INSTALLED will show on the screen.

CAUTION: If a parallel printer is also used on a system where a serial printer is being used, once SERDRV.BAS has been run, the computer will have to be rebooted or reset before printing can be done from the parallel PRINTER Port.

SERDRV.BAS

```
50 REM <<SERDRV.BAS>>
55 REM 8 BITS,NO PARITY,1200 BAUD
100 REM <<SERIAL PRINTER DRIVER>>
110 DIM BUF$(256)
120 Z=ADR("  "):REM TYPE 4 SPACES
130 DATA 104,76,89,228
140 FOR I=0 TO 3
150 READ X
160 POKE Z+I,X
170 NEXT I
180 DCB=768
190 DATA 90,1,83,0,0,0,1,0,6,0,18,240
200 FOR I=0 TO 11
210 READ X
220 POKE DCB+I,X
230 NEXT I
240 X=USR(Z)
250 A=ADR(BUF$)
260 X=INT(A/256)
270 POKE DCB+5,X
280 POKE DCB+4,A-X*256
290 DATA 195,0,239,195,25,239
300 FOR I=0 TO 5
310 READ X
320 POKE A+I,X
330 NEXT I
```

```

340 POKE DCB+2,ASC("W")
350 POKE DCB+3,128
360 POKE DCB+10,6
370 X=USR(Z)
380 POKE DCB+2,ASC("S")
390 POKE DCB+3,0
400 POKE DCB+10,0
410 POKE DCB+11,239
420 X=USR(Z)
430 GOSUB 2000
440 POKE DCB+2,ASC("W")
450 POKE DCB+3,128
460 POKE DCB+8,31
461 REM NUMBER OF PROGRAM BYTES
470 POKE DCB+10,31
480 X=USR(Z)
490 PRINT "SERIAL DRIVER INSTALLED"
500 END
2000 DATA 243,6,9,175,205,16,239
2001 DATA 55,121,205,16,239,16
2002 DATA 251,251,201,211,81,31
2003 DATA 22,200,21,32,253,201
2004 DATA 219,80,0,230,2,201
2010 FOR I=0 TO 30
2020 READ X
2030 POKE A+I,X
2040 NEXT I
2050 RETURN

```

Baud rate is determined by the second variable in Line 2003. The above listing is for a baud rate of 1200. These are the possibilities:

1200 Baud:	2003 DATA 22,200,21,32,253,201
2400 Baud:	2003 DATA 22,100,21,32,253,201
4800 Baud:	2003 DATA 22,48,21,32,253,201
9600 Baud:	2003 DATA 22,22,21,32,253,201

III.1.F. ATRMON.BAS and the ATR8000 Monitor

The ATR8000's monitor (ATRMON) can be accessed after the ATR8000 terminal program, Auto-Term, is run. (This terminal program is supplied with CP/M.) The following ATARI BASIC program, ATRMON.BAS, emulates ATRMON. Changes to the ATR8000 monitor can be made using ATRMON.BAS. **Alterations are lost when the ATR8000 is reset because the monitor is automatically reread into memory from ROM when the system is reset;** alterations made to ATRMON (after the Auto-Term program is run) are also lost when the ATR8000 is reset.

When ATRMON.BAS is run, a question mark prompt appears on the screen (?). Four commands can be entered here:

DIAGRAM 29: ATR8000 Monitor Commands

<u>Command</u>	<u>Action</u>
Daaaa	Dumps 128 bytes of memory on the screen (a block). <aaaa> represents the memory location. For example, DO will dump the first 128 bytes of memory.
Maaaa	Command to examine and change memory.
Gaaaa	Execute at a particular location.
B	Boots CP/M when a CP/M disk is in Drive A. (This command is for ATRMON, not ATRMON.BAS.)

To access the ATR8000 monitor from ATARI DOS or OS/A+, enter and run ATRMON.BAS. Then use the monitor commands in Diagram 29.

ATRMON.BAS — An ATARI BASIC Program

```
100 REM <<ATRMON.BAS>>
110 REM <<D=DUMP MEM>>
120 REM <<M=EXAMINE MEM>>
130 REM <<G=EXECUTE AT ADD>>
140 DIM X$(16)
150 X$="0123456789ABCDEF"
160 DIM C$(1)
170 DIM BUF$(256)
180 DIM H$(5)
190 REM SET UP USR Z
200 Z=ADR("  ")
210 DATA 104,76,89,228
220 FOR I=0 TO 3
230 READ X
```

```

240 POKE Z+I,X
250 NEXT I
260 REM PRESET DCB BUFFER
270 DCB=768
280 CMD=770:REM "R","W","G","S"
290 AX1=778:REM BYTE COUNT OR LOW ADD
300 AX2=779:REM HIGH ADD
310 DIR=771:REM SIO CONTROL
315 NUM=776:REM BYTE COUNT FOR SIO
320 IN=64:REM INPUT TO BUFFER
330 OUTB=128:REM OUTPUT WITH BUFFER
340 OUT=0:REM OUTPUT WITHOUT BUFFER
350 DATA 90,1,0,0,0,0,1,0,0,0,0,0
360 REM "Z"=90,DEVICE I.D.
370 FOR I=0 TO 11
380 READ X
390 POKE DCB+I,X
400 NEXT I
410 REM SET UP BUFFER ADDRESS
420 A=ADR(BUF$)
430 X=INT(A/256)
440 POKE DCB+5,X
450 POKE DCB+4,A-X*256
460 INPUT H$
462 C$=H$(1,1)
465 H$=H$(2,LEN(H$))
470 IF ASC(C$)=ASC("D") THEN 600
480 IF ASC(C$)=ASC("M") THEN 1000
490 IF ASC(C$)=ASC("G") THEN 1500
500 GOTO 460
600 REM DUMP MEMORY
610 GOSUB 2000
620 GOSUB 5000
680 POKE CMD,ASC("R")
690 POKE DIR,IN
700 POKE AX1,128
705 POKE NUM,128
710 GOSUB 9000
720 N=0
725 M=D
730 FOR I=0 TO 127
740 IF N>0 THEN 760
745 D=M+I
747 GOSUB 4000
748 PRINT H$;
749 PRINT " ";
750 N=8
760 D=PEEK(A+I)
770 GOSUB 4000
780 PRINT H$(3,4);
790 PRINT " ";
800 N=N-1
801 IF N>0 THEN 820
802 FOR F=7 TO 0 STEP -1
803 G=PEEK((A+I)-F)
804 IF G<32 THEN 808

```

```

805 IF G>121 THEN 808
806 PRINT CHR$(G);
807 GOTO 809
808 PRINT ".";
809 NEXT F
815 PRINT
820 NEXT I
830 GOTO 460
1000 PRINT H$;
1010 PRINT " ";
1020 GOSUB 2000
1030 GOSUB 5000
1035 M=D
1040 POKE CMD,ASC("R")
1050 POKE DIR,IN
1060 POKE AX1,1
1065 POKE NUM,1
1070 GOSUB 9000
1080 D=PEEK(A)
1090 GOSUB 4000
1100 PRINT H$(3,4);
1110 INPUT H$
1120 IF ASC(H$)=ASC(".") THEN 460
1130 IF LEN(H$)=0 THEN 1190
1140 GOSUB 2000
1150 POKE A,D
1160 POKE CMD,ASC("W")
1170 POKE DIR,OUTB
1180 GOSUB 9000
1190 M=M+1
1200 D=M
1210 GOSUB 5000
1220 GOSUB 4000
1230 PRINT H$;
1240 PRINT " ";
1250 GOTO 1040
1500 PRINT H$
1510 GOSUB 2000
1520 GOSUB 5000
1530 POKE CMD,ASC("G")
1540 POKE DIR,OUT
1550 GOSUB 9000
1560 GOTO 460
2000 IF LEN(H$)<1 OR LEN(H$)>4 THEN 2099
2010 D=0
2020 FOR J=1 TO LEN(H$)
2030 K=ASC(H$(J,J))-ASC("0")
2040 IF K<0 THEN 2099
2050 IF K<10 THEN 2090
2060 K=K-7
2070 IF K<10 THEN 2099
2080 IF K>15 THEN 2099
2090 D=(D*16)+K
2095 NEXT J
2096 RETURN
2099 PRINT "INVALID HEX DATA"

```

```

2100 RETURN
4000 FOR J=4 TO 1 STEP -1
4010 K=D
4020 D=INT(D/16)
4030 HS(J,J)=XS(K-(D*16)+1)
4040 NEXT J
4050 RETURN
5000 Y=INT(D/256)
5010 POKE AX2,Y
5020 POKE AX1,D-Y*256
5030 POKE CMD,ASC("S")
5040 POKE DIR,OUT
5050 GOSUB 9000
5060 RETURN
9000 X=USR(Z)
9010 RETURN

```

PROGRAM NOTES:

The following information is for users that are interested in how ATRMON.BAS works. It is not necessary for most users to know this information. For the average user, it is adequate to learn the monitor commands without worrying about the internal actions.

The ATARI talks to peripherals (like the ATR8000) with a five byte command frame. This is accessed through the ATARI SIO. The five bytes (in order) are:

Device I.D. | Command | Aux 1 | Aux 2 | Checksum

The first byte, Device I.D., tells the ATARI what device is being used. For example, a disk drive is a device.

The command is simply the command that the ATARI is telling the peripheral to perform.

The meanings of Aux 1 and Aux 2 vary, depending on the peripheral.

Checksum is a safety device that guarantees proper data transfer. It is generated and checked by the ATARI SIO routine.

In the ATR8000 a new device has been created, the ASCII Z device. This device, Z, has four commands. Some of these commands define Aux 1 and Aux 2. The checksum will not be further explained here, as it is generated by the ATARI SIO.

<u>I.D.</u>	<u>CMD</u>	<u>Aux 1</u>	<u>Aux 2</u>
Z	S	Low order of address	High order of address

"S" is the Set command. It is used to set the Z80's pointer to the beginning memory location for a read, a write, or an execute. S is always done before R, W and G.

For S, Aux 1 contains the low order of the address and Aux 2 contains the

high order of the address. Therefore, for an address <HHLL>, Aux 1 is LL and Aux 2 is HH.

<u>I.D.</u>	<u>CMD</u>	<u>Aux 1</u>	<u>Aux 2</u>
<u>Z</u>	<u>R</u>	Byte count	<u> </u>

"R" is the Read command. It can be used to read a single memory location, or a whole block. The amount of data read is determined by the value in Aux 1. Aux 2 is not used here.

<u>I.D.</u>	<u>CMD</u>	<u>Aux 1</u>	<u>Aux 2</u>
<u>Z</u>	<u>W</u>	Bytes to expect	<u> </u>

"W" is the Write command. The amount of data that is to be written is determined by Aux 1. Aux 2 is not used here.

<u>I.D.</u>	<u>CMD</u>	<u>Aux 1</u>	<u>Aux 2</u>
<u>Z</u>	<u>G</u>	<u> </u>	<u> </u>

"G" is the execute command. Aux 1 and Aux 2 are not used here.

The above describes the internal working of ATRMON.BAS and the new device I.D., Z. The following describes the internal actions that ensue when an external monitor command is used (D, M, or G).

Once in ATRMON, you have a choice of three commands: D, M and G (described on Page 64):

D

When Daaaa is entered at the monitor, the monitor internally does the following:

1. Does a Z and S, setting the Z80 pointer to the specified address.
2. Does a Z and R, with Aux 1 containing 128.

The resulting action is that an entire block of memory is dumped on the display screen. The block begins at the specified address, aaaa.

M

When Maaaa is entered at the monitor, the monitor internally does the following:

1. Does a Z and S, setting the Z80 pointer to the specified address.
2. Does a Z and R, with Aux 1 containing 1.

The resulting action is that the specified address is displayed on the screen. The M command displays addresses one at a time so that you can alter them.

G

When Gaaaa is entered at the monitor, the monitor internally does the following:

1. Does a Z and S, setting the Z80 pointer to the specified address.
2. Does a Z and G.

The resulting action is the execution of the specified address.

III.1.G. Using More Than Two Drives With ATARI DOS

To run more than two drives under ATARI DOS, you must patch the DOS. This is explained in Appendix B of the ATARI DOS manual. This patch is only necessary for ATARI DOS, not OS/A+ 4.1.

The DOS is patched for more than two drives by doing the following:

- #1 Boot ATARI DOS. (Type DOS<return> after the READY prompt.)
- #2 Test the DOS by trying to access D3. (Type a <return>, then: D3:<return>.) The computer should respond with the message: ERROR 160. If it accesses the drive, the DOS has already been patched.
- #3 From the ATARI DOS menu, select B (RUN BASIC CARTRIDGE).
- #4 We'll now look to see how many drives the DOS is currently set for. This is determined by the value in Location 1802.

Type: ?PEEK(1802)<return>. Translate the number displayed on the screen by using the following table:

<u>Number</u>		<u># of Drives</u>
3	=	2 drives
7	=	3 drives
15	=	4 drives

- #5 We'll now change the value in location 1802 to the value that corresponds to the number of drives on your system.

For three drives, type: POKE 1802,7<return>
For four drives, type: POKE 1802,15<return>

When the READY prompt reappears on the screen, the patch has been made.

- #6 To verify that Location 1802 has been changed, type: ?PEEK(1802)<return>. The change you entered in Step 5 should be echoed on the screen.

- #7 To permanently save this change to the ATARI DOS disk, type DOS<return> to return to the ATARI DOS menu.

Type: H<return> (WRITE DOS FILES). You are now asked "WRITE DOS FILES TO WHICH DRIVE?"

Select D1 by typing: 1<return>. The screen will respond "TYPE 'Y' TO WRITE DOS TO DRIVE 1."

Type: Y<return>. The screen will respond "WRITING NEW DOS FILES."

- #8 To test the changes do the following:

Reboot the ATARI. (Turn the power off and then on.)

Type: DOS<return>.

Choose A from the DOS menu. (DISK DIRECTORY)

The screen will show "DIRECTORY—SEARCH SPEC, LIST FILE?"

Access Drive 3 by typing: D3<return>.

If the DOS has been properly patched, Drive 3 will be accessed. If you have four drives and patched the DOS for four, also try accessing Drive 4.

III.2. OS/A+ 4.1

OS/A+ 4.1 is available on both 5 1/4" and 8" disks. It is booted from a standard disk drive. This section describes OS/A+ as it relates to the ATR8000. For detailed use on how to use this DOS, consult the separate OS/A+ operating manual. **The ATARI 800/400 must have a minimum of 32k RAM to run OS/A+.**

If you are going to run both OS/A+ and CP/M, we suggest that you have both operating systems on the same size of disk. This eliminates having to reconfigure the drive connections before booting and running the different DOSes.

The stipulations for using printers and modems with OS/A+ are the same as the ATARI DOS stipulations. Refer to the ATARI DOS section for this information. As with ATARI DOS operation, it is important to thoroughly understand the conditions that arise when the ATARI 850 is interfaced to the system.

Wherever possible it is best to directly connect peripherals to the ATR8000. This eliminates having to perform special operations before using the peripherals (such as running PRINTOFF.BAS) and eliminates the need to change the connections to use the peripherals for CP/M. (Peripherals must be directly connected to the ATR8000 to work with CP/M.)

ATARI 810 drives may be used with OS/A+, but not as D1: and only for single density operation. Subsection B of this section tells how to use an 810 with OS/A+ 4.1.

Some OS/A+ users have had difficulties using 80 track and 8" drives. OSS has solutions to these problems. If you have any problems with OS/A+, contact OSS for assistance. [Optimized Systems Software, Inc., 10379 Lensdale Avenue, Cupertino, CA 95014. (408)446-3099.]

III.2.A. Booting OS/A+ 4.1

OS/A+ is booted like ATARI DOS is booted. To boot OS/A+ from your ATARI-ATR8000 system:

- STEP 1 Turn the power on the disk drives, the ATR8000 and the TV/monitor.
- STEP 2 Reset the ATR8000. (The reset button is in the back of the ATR8000 enclosure above the power cord.)
- STEP 3 Put the OS/A+ disk in Drive 1. Drive 1 must be a standard drive -- it cannot be an ATARI 810. [D1: could also be a Percom controller drive.]
- STEP 4 Turn the ATARI 800/400 on. If the BASIC cartridge is in the ATARI, the READY prompt will appear. After this prompt, type: DOS<return>. OS/A+ is now booted.

If there isn't a BASIC cartridge in the ATARI when it is powered up with the OS/A+ disk in Drive 1, the DOS will be directly booted.

III.2.B. Using ATARI 810 Drives With OS/A+ 4.1

ATARI 810 drives can be used with OS/A+ with some limitations. They can only be used in single density. For OS/A+ to access an 810, ADOS must be run. After ADOS is run, then refer to an 810 drive as "An" instead of "Dn."

For example, if Drive 1 is a standard drive and Drive 2 is an 810 and you want to use Drive 2 under OS/A+, then you would run ADOS. After ADOS is run you would log onto Drive 1 by typing: D1<return> and you would log onto Drive 2 by typing: A2<return>. So to get a directory of an ATARI 810, you would type: DIR An:*.*

A single density disk in an 810 can be read from and written to after ADOS is run, but not formatted. The single disks must be formatted under ATARI DOS.

For more ADOS information, refer to the OS/A+ manual.

III.3. ATR8000 System ROM

This section is for ATR8000 users that want to know more about the internal workings of the ATR8000. Programmers should use this for reference purposes.

III.3.A. ATR8000 User Accessible Monitor Routines and Variables

This section gives the locations and calling sequences of user accessible I/O routines in the ATR8000 monitor. It also describes a number of important monitor variables that may need to be accessed by user written programs.

ATR8000 subroutines are accessed via a table of JUMP instructions beginning at memory location F000 hex. All monitor calls should be made to these entry points, since the actual addresses of the routines inside the ATR8000 will vary between different releases. Parameter passing conventions for the monitor fall into one of two groups. The character oriented I/O routines all pass data using the A and C registers while the disk routines pass parameters in a 9 byte long disk I/O parameter block pointed to by IX.

Storage for the monitor stack and working variables occupies the top 256 bytes of memory, from FFO0 to FFFF hex. Included are variables used by the monitor resident I/O drivers and interrupt service routines, some of which are described below. Programs should not attempt to write into any locations in this block that are not specifically mentioned below.

III.3.A1. ATR8000 Subroutine Entry Points

F000	JP	COLD	;ATR8000 COLD START ENTRY
F003	JP	WARM	;ATR8000 WARM START ENTRY
F006	JP	CONST	;CONSOLE INPUT STATUS TEST
F009	JP	CONIN	;CONSOLE INPUT
F00C	JP	CONOUT	;CONSOLE OUTPUT
F00F	JP	DISKIO	;EXECUTE DISK OPERATION
F012	JP	LISTOUT	;LIST DEVICE OUTPUT
F015	JP	LISTST	;LIST DEVICE STATUS
F018	JP	REINIT	;CONSOLE REINITIALIZATION

<u>Function</u>	<u>Parameters</u>	<u>Description</u>
COLD	IN: none OUT: does not return	Perform cold start initialization of ATR8000 monitor and enter command mode.
WARM	IN: none OUT: does not return	Enter ATR8000 monitor command mode with no reinitialization.
CONST	IN: none OUT: status in A	Test for data ready in console input FIFO and return status in A. If data is available A=0, else A=FF hex.
CONIN	IN: none OUT character in A	Return character from console input FIFO in A. If FIFO is empty then loop until character is input.
CONOUT	IN: character in C OUT: none	Output character passed in C to the console output device.
DISKIO	IN: OUT: } see chart	Execute disk operation. See Disk I/O Control Block Format Chart on the following page.
LISTOUT	IN: character in C OUT: none	Output character to list device without checking for ready status.
LISTST	IN: none OUT: status in A	List device status. A=0 if printer is ready to print.
REINIT	IN: none OUT: none	Reinitialize console I/O after performing a disk operation.

III.3.A2. Disk I/O Control Block Format

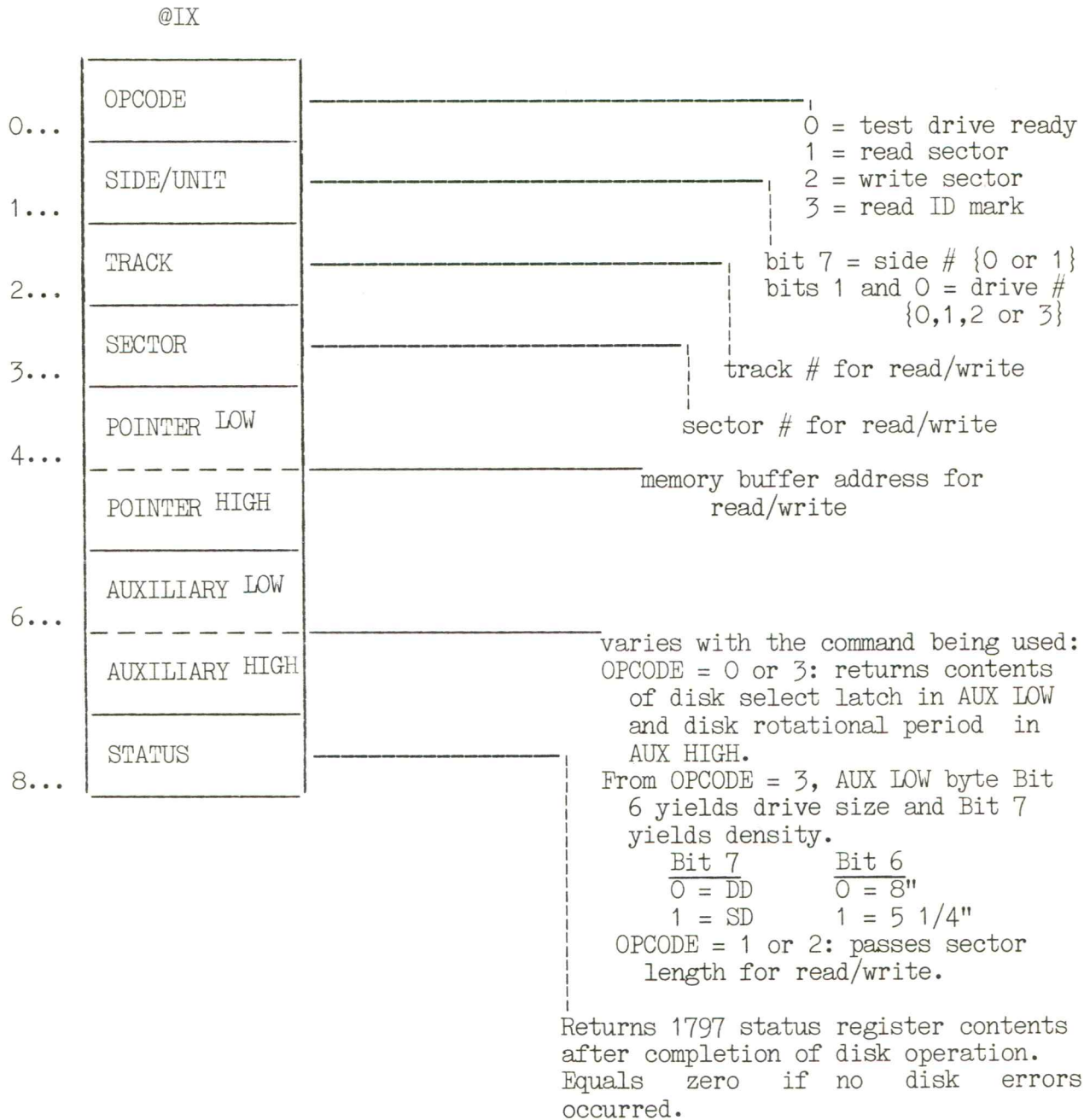

III.3.B. ATR8000 Memory Map

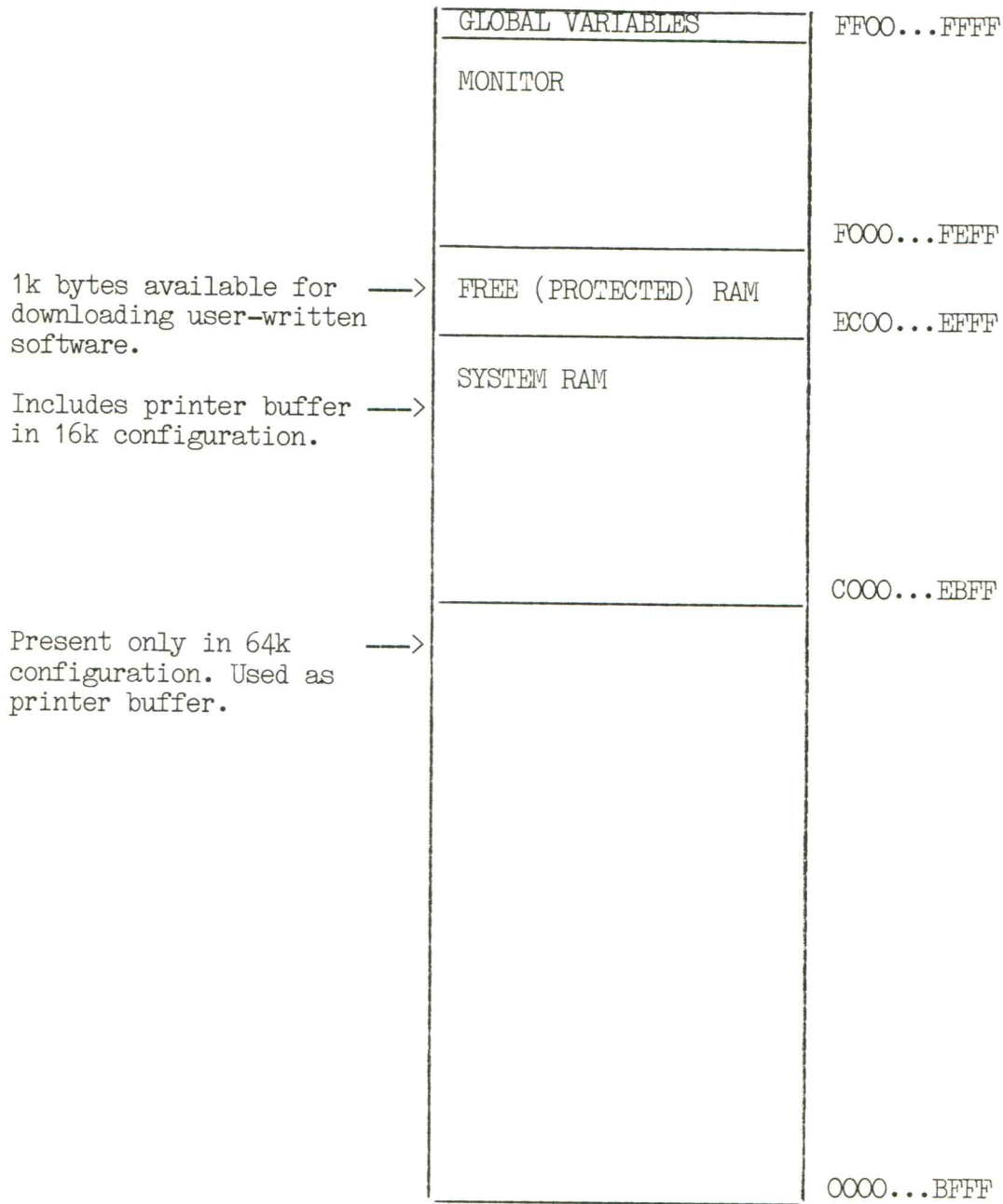

```

C      ;      ... VARIABLES FOR DISK FORMAT FUNCTION ...
C      ;
C      FMTSTUF EQU      $
C      FRMPTR: DEFS    2      ; POINTER TO FORMAT DATA TABLE
C      SKWPTR: DEFS    2      ; POINTER TO SKEW TABLE
C      FILL:   DEFS    2      ; EMPTY SECTOR FILL DATA
C      NTRAKS: DEFS    1      ; NUMBER OF TRACKS
C      NSECTS: DEFS    1      ; NUMBER OF SECTORS
C      TRKSIZ: DEFS    2      ; TRACK LENGTH IN BYTES
C
C      FMTLEN EQU      $-FMTSTUF
C
C      SEQNUM: DEFS    2      ; TEMP SECTOR SEQUENCE NUMBER
C      SEQPTR: DEFS    2      ; TEMP ERROR LOG TABLE POINTER
C      TRKPTR: DEFS    2      ; POINTER TO START OF TRACK IMAGE
C      ;
C      ;
C      ;      ... LOCAL VARIABLES FOR DISK HANDLER ...
C      ;
C      CMDBYT: DEFB    0      ; COMMAND BYTE FOR READS/WRITES
C      RWTRY:  DEFB    0      ; READ/WRITE RETRY COUNT
C      TICKS:  DEFW    0      ; FREE RUNNING MILLISECOND COUNTER
C      DRVTMR: DEFB    0      ; DISK ACTIVITY TIMER
C      ;
C      ;
C      ;
C      IOBUFF EQU      0C100H      ; ATARI I/O BUFFER
C      LEN     EQU      512
C      ;
C      TRKBUF EQU      IOBUFF+LEN  ; TRACK BUFFER FOR READS
C      ;
C      ;
C      .DEPHASE
C      ;
C      ;
C      LAST   EQU      $
C      END
1073

```

IV. Expanding the ATR8000

Because of its versatility, the ATR8000 system is capable of expanding as you can afford to add to it. To add components to the ATR8000 after the initial connection, find the hardware connection section that best describes all of your equipment and follow the guidelines. The following subsections contain tips and instructions.

IV.1. Converting to 64k

Read this subsection carefully to convert the 16k ATR8000 to 64k. If you do not feel competent to make this change (or if you're unsure), send your ATR8000 to us to have this done. The charge for us making the conversion is \$20 plus the cost of the upgrade.

To make the conversion:

- STEP 1 Turn the power off and unplug the ATR8000. Do NOT repower or plug in the unit before this entire process has been completed.
- STEP 2 Consult Section II.7.A and make the necessary changes in J1, J2, J3, J4, J5, J6, and J8.
- STEP 3 Remove the 16k RAM I.C.'s from sockets U1 to U8. These sockets are directly above J3 - J6 on the ATR8000 circuit board. A thin screwdriver blade may be used to gently pry the chips from the sockets. Store these chips in the conductive foam the 64k RAM chips came in.
- STEP 4 Put the eight 64k Dynamic RAM chips (200 nanoseconds) into the now-empty U1 - U8 sockets. Make sure that Pin 1 on each chip (marked by a small circle in the upper left corner or by a semicircular notch cut in the upper edge of the chip) is placed in the socket so that it matches Pin 1 on the socket (marked by a semicircular cut in the upper edge of the socket). Pin 1 on the sockets and the 64k D RAMs should point towards the white letters denoting U1 - U8 on the ATR8000 circuit board.
- STEP 5 Carefully inspect the circuit board to insure that the above procedure was performed EXACTLY. If you turn the power on and did not correctly follow this procedure, the ATR8000 may be damaged.

IV.2. Adding Drives, a Printer, or a Modem

If you add a printer or a modem (or buy a different one), read all information pertaining to the connection and configuration BEFORE installing it. To add disk drives, follow the instructions for internally configuring a drive, making sure that each drive on the system has a unique drive number.

Remember that if you want to use more than two drives under ATARI DOS, you must patch the DOS. This is explained in the ATARI DOS section of this manual.

After making any changes to the ATR8000 system, carefully inspect the changes for accuracy before repowering and testing the system.

IV.3. Adding CO-POWER-88™

CO-POWER-88™ is a 16-bit, 8088 coprocessor available with 128k or 256k RAM. This SWP coprocessor can be added to the 64k ATR8000. CO-POWER-88 supports CP/M-86 and MSDOS, DOSes that the IBM-PC uses.

CO-POWER-88 is three interconnected circuit boards: the Z-80 Adpater Board, the Auxiliary Power Board and the Main Processor Board. The Z-80 chip from the ATR8000's circuit board is removed and inserted into the Z-80 Adapter Board. The Z-80 Adpater Board is then plugged into the ATR8000's Z-80 socket. A ribbon cable connects this board to the Main Processor Board.

The Main Processor Board attaches to the ATR8000 enclosure under the ATR8000's circuit board. Once secured, the Auxiliary Power Board is connected to the Main Processor Board. Two power leads connect between the Auxiliary Power Board and the ATR8000's power supply.

CO-POWER-88 runs either CP/M-86 or MSDOS. First the ATR8000 system is booted with CP/M 2.2, then you have the option of entering CP/M-86 or MSDOS by typing a simple command. CP/M-86 and CP/M 2.2 files are compatible and can reside on the same disks. (CP/M-86 command files have .CMD as the extent while CP/M 2.2 files have .COM as the extent.) The CP/M 2.2 disk is removed from the computer before MSDOS is entered. MSDOS cannot share disks with CP/M 2.2.

The ATARI 800/400, the ATR8000 and CO-POWER-88 combine to give you an extraordinarily versatile computer system. With this system you have a 6502 processor, a Z-80 processor and an 8088 processor and you can run ATARI DOS, OS/A+, CP/M 2.2, CP/M-86 and MSDOS!

Call or write for further information about CO-POWER-88. [SWP Microcomputer Products, Inc., 2500 E. Randol Mill Rd., Suite 125, Arlington, TX 76011. (817)469-1181.]

V. Warranty, Software License and Service Policy

ATR8000 Warranty

The ATR8000 is under warranty for 90 days from the original end user's date of purchase. To be valid the enclosed registration card must be thoroughly completed and mailed to SWP Microcomputer Products, Inc., within 10 days from date of purchase. The serial number on the ATR8000's circuit board must be entered in the proper place on the registration card.

SWP is not responsible for any changes the user makes to the ATR8000 circuit board, including the user installing the 64k upgrade, or the user improperly connecting and configuring the ATR8000 and any peripherals. The user is responsible for correctly connecting all interface cables in the proper way (i.e., matching Pin 1s on the connectors on both ends of the cable). Detailed instructions for such connections are contained in this ATR8000 manual.

SWP is not responsible for any damage done to peripherals connected to the ATR8000 system. Again, all connections are thoroughly explained. If the user has any uncertainties about connections, it is his responsibility to consult his dealer BEFORE connecting his system.

SWP is responsible for replacing malfunctioning components on the under-warranty ATR8000. This responsibility is void if the user has damaged the circuit board in any way. This warranty becomes void if the end user resells the ATR8000.

The user is responsible for shipping charges to SWP Microcomputer Products, Inc., for any warranty work. SWP will pay return shipping within the continental United States.

Warranty for Drives Purchased From SWP

Disk drives purchased from SWP are under warranty for 90 days from the original end user's purchase date. This warranty covers the drive and included power supply. To be valid, the end user must complete and return the enclosed registration card.

SWP is responsible for thoroughly testing drives before shipping. Any malfunctions in an under-warranty drive will be repaired without charge if the user has not tampered with the drive and power supply. The user is responsible for thoroughly understanding drive configuration before configuring it. This user responsibility includes consulting his dealer about any uncertainties BEFORE configuring the drive.

The user is responsible for shipping charges to SWP when sending an under-warranty drive in for repairs. SWP is responsible for return shipping charges within the continental United States.

Repairs on Components Not Under Warranty

Once the warranty has expired, or if the user has voided the warranty, SWP will repair malfunctioning ATR8000s and other peripherals sold by SWP for repair charges. These charges will include the cost of materials used in the repair and labor.

The user will be assessed for all time spent analyzing and repairing the unit. Any pertinent information sent by the user regarding the nature of the malfunction will decrease the analysis time, and, therefore, the charges assessed.

The total charges will depend upon the severity of damage. The user is responsible for shipping charges to and from SWP.

Injury to Customer

SWP assumes no responsibility for any injury to CUSTOMER resulting directly or indirectly from the operation of, or connecting to, or configuring of the ATR8000 and its peripherals. This manual fully cautions CUSTOMER to turn off the power and unplug the unit from electrical outlets when performing any operation in potentially hazardous situations. SWP is not responsible for any injury incurred if CUSTOMER makes any cuts in the traces of the ATR8000 circuit board (such as changes for jumper options).

CUSTOMER assumes full responsibility for all of his actions in dealing with the ATR8000 system. If CUSTOMER is unsure of his ability to perform any such operations, it is his duty to consult a technical expert.

Software Information

ALL SWP PROGRAMS ARE LICENSED ON AN "AS IS" BASIS WITHOUT WARRANTY.

SWP shall have no liability or responsibility to CUSTOMER or to any other person or entity with respect to liability, loss or damage caused or alleged to be caused directly or indirectly by SWP computer programs or equipment, including but not limited to any interruption of service, loss of business or anticipatory profits or consequential damages resulting from the use or operation of such computer programs (or equipment). By purchasing a SWP product, user agrees to these conditions.

Software License

- 1). SWP Microcomputer Products, Inc., grants to CUSTOMER a nonexclusive, paid-up license to use on CUSTOMER's computer the SWP computer software received. Title to the media on which the software is recorded (disk) or stored (ROM) is transferred to the CUSTOMER, but not title to the software.
- 2). In consideration for this license, CUSTOMER shall not reproduce copies of SWP's software except to reproduce the number of copies required to use on the CUSTOMER's computer (if the software allows a backup copy to be made), and shall include the SWP's copyright notice on all copies of software reproduced in whole or in part.
- 3). CUSTOMER may resell SWP's software (modified or not, in whole or in part), provided CUSTOMER has purchased one copy of the software for each one resold.

The provisions of this Software License (paragraphs 1, 2 and 3) shall also be applicable to third parties purchasing such software from CUSTOMER.

Software Problems

If you are having trouble getting a particular ATARI or CP/M program to run on the ATR8000, give us a call. It's possible that there will be a simple solution. If we don't know the answer, we'll do our best to resolve the problem.

SWP Service Policy

The following is our standard policy for handling repairs and problems. Whenever you send hardware and/or software to us, be sure to include a note thoroughly describing any problems. If you are shipping us hardware, be sure to clearly mark the repair authorization number on the outside of the shipping carton.

Service Policy:

Rather than trying to solve most problems over the phone, we prefer to solve them here at our factory. It usually takes a lot less time for us to solve a problem here and it helps keep our phone lines available.

If you think you are having problems relating to the ATR8000, call us and tell us the symptoms. If we think something is wrong, we'll give you a repair authorization number. Clearly mark this number on the outside of the shipping carton.

If there is a problem and your unit is under warranty, we'll repair it and pay return shipping (in the continental U.S.).

If the unit is not broken, you may be assessed for labor and return shipping. If the unit is out of warranty and the problem is not one we deem to be an internal fault, you may be charged for labor and return shipping.

